

Recognized as an
American National Standard (ANSI)

IEEE Std 112-1996
(Revision of IEEE Std 112-1991)

IEEE Standard Test Procedure for Polyphase Induction Motors and Generators

Sponsor
**Electric Machines Committee
of the
IEEE Power Engineering Society**

Approved 19 September 1996
IEEE Standards Board

Approved 27 February 1997
American National Standards Institute

Abstract: Instructions are given for conducting and reporting the more generally applicable and acceptable tests to determine the performance characteristics of polyphase induction motors and generators. Electrical measurements, performance testing, temperature tests, and miscellaneous tests are covered.

Keywords: generators, motors, tests

The Institute of Electrical and Electronics Engineers, Inc.
345 East 47th Street, New York, NY 10017-2394, USA

Copyright © 1997 by the Institute of Electrical and Electronics Engineers, Inc.
All rights reserved. Published 1997. Printed in the United States of America

ISBN 1-55937-891-3

No part of this publication may be reproduced in any form, in an electronic retrieval system or otherwise, without the prior written permission of the publisher.

IEEE Standards documents are developed within the IEEE Societies and the Standards Coordinating Committees of the IEEE Standards Board. Members of the committees serve voluntarily and without compensation. They are not necessarily members of the Institute. The standards developed within IEEE represent a consensus of the broad expertise on the subject within the Institute as well as those activities outside of IEEE that have expressed an interest in participating in the development of the standard.

Use of an IEEE Standard is wholly voluntary. The existence of an IEEE Standard does not imply that there are no other ways to produce, test, measure, purchase, market, or provide other goods and services related to the scope of the IEEE Standard. Furthermore, the viewpoint expressed at the time a standard is approved and issued is subject to change brought about through developments in the state of the art and comments received from users of the standard. Every IEEE Standard is subjected to review at least every five years for revision or reaffirmation. When a document is more than five years old and has not been reaffirmed, it is reasonable to conclude that its contents, although still of some value, do not wholly reflect the present state of the art. Users are cautioned to check to determine that they have the latest edition of any IEEE Standard.

Comments for revision of IEEE Standards are welcome from any interested party, regardless of membership affiliation with IEEE. Suggestions for changes in documents should be in the form of a proposed change of text, together with appropriate supporting comments.

Interpretations: Occasionally questions may arise regarding the meaning of portions of standards as they relate to specific applications. When the need for interpretations is brought to the attention of IEEE, the Institute will initiate action to prepare appropriate responses. Since IEEE Standards represent a consensus of all concerned interests, it is important to ensure that any interpretation has also received the concurrence of a balance of interests. For this reason, IEEE and the members of its societies and Standards Coordinating Committees are not able to provide an instant response to interpretation requests except in those cases where the matter has previously received formal consideration.

Comments on standards and requests for interpretations should be addressed to:

Secretary, IEEE Standards Board
445 Hoes Lane
P.O. Box 1331
Piscataway, NJ 08855-1331
USA

Note: Attention is called to the possibility that implementation of this standard may require use of subject matter covered by patent rights. By publication of this standard, no position is taken with respect to the existence or validity of any patent rights in connection therewith. The IEEE shall not be responsible for identifying all patents for which a license may be required by an IEEE standard or for conducting inquiries into the legal validity or scope of those patents that are brought to its attention.

Authorization to photocopy portions of any individual standard for internal or personal use is granted by the Institute of Electrical and Electronics Engineers, Inc., provided that the appropriate fee is paid to Copyright Clearance Center. To arrange for payment of licensing fee, please contact Copyright Clearance Center, Customer Service, 222 Rosewood Drive, Danvers, MA 01923 USA; (508) 750-8400. Permission to photocopy portions of any individual standard for educational classroom use can also be obtained through the Copyright Clearance Center.

Introduction

(This introduction is not part of IEEE Std 112-1996, IEEE Standard Test Procedure for Polyphase Induction Motors and Generators.)

This standard provides the basic test procedure for evaluating the performance of a polyphase induction motor or generator of any size. The standard has been revised many times due to improvements in instrumentation and increased knowledge of the art of measurement. The emphasis on energy conservation, legislated values for motor efficiency, and the desire for harmonization with Canadian Standard C390 and the requirements for test accuracy under the National Voluntary Laboratory Accreditation Program (NAVLAP®) certification procedure warranted this further review. The accuracy of the test procedure for measuring efficiency has been verified by extensive comparison testing conducted by the National Electrical Manufacturers Association (NEMA) and the Accredited Standards Committee C50. The revision was carefully written so that references in contracts to certain types of tests for machines will apply equally to both this revision and its prior 1991 version.

The following is a list of participants of the Induction Power Subcommittee's effort of IEEE Std 112-1996:

Walter J. Martiny, *Chair*

Paul Anderson
John C. Andreas
Lloyd W. Buchanan
Paul G. Cummings
Roger H. Dougherty

James H. Dymond
Nirmal K. Ghai
Franklin H. Grooms
John S. Hsu
James L. Kirtley, Jr.

Joseph A. Kline
Edward J. Michaels
Randy R. Schoen
Stephen Stretz
James W. York

The following persons were on the balloting committee:

Lloyd W. Buchanan
Stanley S. Burns
Douglas H. Cashmore
Ching Chuen Chan
Michael J. Costello
Jack L. Craggs
James H. Dymond
Raymond D. Findlay

Paul C. Gaberson
Jonathan D. Gardell
Nirmal K. Ghai
Robert J. Harrington
Thomas A. Higgins
John S. Hsu
James Glen Karolyi
Thomas A. Lipo
Walter J. Martiny

Nigel P. McQuin
James R. Michalec
Nils E. Nilsson
James A. Oliver
Pragasen Pillay
M. Azizur Rahman
Randy R. Schoen
Jan Stein

When the IEEE Standards Board approved this standard on 19 September 1996, it had the following membership:

Donald C. Loughry, *Chair*

Richard J. Holleman, *Vice Chair*

Andrew G. Salem, *Secretary*

Gilles A. Baril
Clyde R. Camp
Joseph A. Cannatelli
Stephen L. Diamond
Harold E. Epstein
Donald C. Fleckenstein
Jay Forster*
Donald N. Heirman

Ben C. Johnson
E. G. "Al" Kiener
Joseph L. Koepfinger*
Stephen R. Lambert
Lawrence V. McCall
L. Bruce McClung
Marco W. Migliaro
Mary Lou Padgett
John W. Pope

Jose R. Ramos
Arthur K. Reilly
Ronald H. Reimer
Gary S. Robinson
Ingo Ritsch
John S. Ryan
Chee Kiow Tan
Leonard L. Tripp
Howard L. Wolfman

*Member Emeritus

Also included are the following nonvoting IEEE Standards Board liaisons:

Satish K. Aggarwal
Alan H. Cookson
Chester C. Taylor

Rochelle L. Stern
IEEE Standards Project Editor

Contents

1.	Overview.....	1
1.1	Scope.....	1
1.2	Purpose.....	1
2.	References.....	1
3.	General tests.....	2
3.1	Types of tests	2
3.2	Choice of tests.....	2
3.3	Use of this standard.....	2
3.4	Tests with load	2
3.5	Tests with rotor locked.....	3
3.6	Precautions.....	3
4.	Measurements	3
4.1	Electrical	3
4.2	Resistance	5
4.3	Mechanical.....	6
4.4	Procedure	7
4.5	Safety	8
5.	Types of losses.....	8
5.1	Stator I^2R loss	8
5.2	Rotor I^2R loss.....	9
5.3	Core loss and friction and windage loss (no-load test).....	9
5.4	Stray-load loss.....	10
5.5	Brush-contact loss.....	14
6.	Determination of efficiency.....	14
6.1	General.....	14
6.2	Test methods for efficiency	15
6.3	Test Method A—Input-output	15
6.4	Test Method B—Input-output with loss segregation.....	16
6.5	Test Method C—Duplicate machines.....	19
6.6	Test Method E or E1—Electrical power measurement with loss segregation.....	21
6.7	Test Method F or F1—Equivalent circuit.....	22
6.8	Test Method C/F, E/F, or E1/F1—Equivalent circuit calibrated with one load point.....	28
6.9	Power factor.....	29
7.	Other performance tests	30
7.1	Rotor voltage.....	30
7.2	Locked-rotor tests	30
7.3	Tests for speed-torque and speed-current.....	31
7.4	Correction of data for speed-torque, speed-current, and locked-rotor tests run at reduced voltage.....	35

8.	Temperature test.....	35
8.1	Purpose.....	35
8.2	General instructions	35
8.3	Methods of measuring temperatures.....	36
8.4	Temperature readings.....	39
8.5	Measurement of ambient temperature	40
8.6	Procedure	40
8.7	Temperature rise	41
9.	Miscellaneous tests	42
9.1	Insulation resistance.....	42
9.2	High-potential test.....	42
9.3	Winding resistance measurements.....	42
9.4	Shaft currents and bearing insulation.....	43
9.5	Noise	44
9.6	Balance and vibration	44
9.7	Overspeed	45
10.	Forms	46
10.1	Form A—Method A.....	46
10.2	Form B—Method B	47
10.3	Form C—Method C	49
10.4	Form E-E1—Method E-E1	51
10.5	Form F1—Method F-F1	53
10.6	Form F2—Method F.....	54
10.7	Form F3—Methods F, F1, C/F, E/F, and E/F1	55
ANNEXES		
A (informative)	Typical report of test form for routine tests on induction machines.....	56
B (informative)	Typical report of test form for induction machines	57
C (informative)	Bibliography	58

IEEE Standard Test Procedure for Polyphase Induction Motors and Generators

1. Overview

1.1 Scope

This standard covers instructions for conducting and reporting the more generally applicable and acceptable tests of polyphase induction motors and generators. Many of the tests described may be applied to both motors and generators, as needed, and no attempt is made to partition the test procedure into clauses applying to motors and subclauses that separately apply to motors or to generators. Whenever the term *motor* is used, it is to be understood that it may be replaced by the term *generator*, if applicable. Since polyphase power systems are almost universally three-phase systems the equations in this standard have been written specifically for three phases. When the test is performed on other than three-phase power, the equations shall be modified appropriately.

1.2 Purpose

Instructions for conducting and reporting the more generally applicable and acceptable tests are covered to determine the performance and characteristics of polyphase induction motors and generators. Additional tests, not specified herein, may be required to satisfy specific research or application needs. These procedures shall not be interpreted as requiring the performing of any specific test in a given transaction.

2. References

This standard shall be used in conjunction with the following standards. When the following standards are superseded by an approved revision, the latest revision shall apply.

IEEE Std 4-1995, IEEE Standard Techniques for High-Voltage Testing (ANSI).¹

IEEE Std 43-1974 (Reaff 1991), IEEE Recommended Practice for Testing Insulation Resistance of Rotating Machinery (ANSI).

¹IEEE publications are available from the Institute of Electrical and Electronics Engineers, 445 Hoes Lane, P.O. Box 1331, Piscataway, NJ 08855-1331, USA.

IEEE Std 85-1973 (Reaff 1986), IEEE Standard Test Procedure for Airborne Sound Measurements on Rotating Electrical Machinery (ANSI).²

IEEE Std 118-1978 (Reaff 1992), IEEE Standard Test Code for Resistance Measurements (ANSI).

IEEE Std 119-1974, IEEE Recommended Practice for General Principles of Temperature Measurement as Applied to Electrical Apparatus (ANSI).³

IEEE Std 120-1989, IEEE Master Test Guide for Electrical Measurements in Power Circuits (ANSI).

3. General tests

3.1 Types of tests

Polyphase induction machines are normally given a routine test, but they may also be given additional tests.

For typical routine tests refer to NEMA MG 1-1993 [B3]⁴ parts 12 and 20.

A typical form for reporting routine test data is shown in Annex A. A typical form for reporting additional test data is shown in Annex B.

3.2 Choice of tests

A complete list of tests covered by this standard is given in the table of contents in clauses 6 through 9. Alternate methods are described for making many of the tests suitable for different sizes and types of machines and different conditions. In some cases, the preferred method is indicated.

The schedule of factory and field tests that may be required on new equipment is normally specified by applicable standards or by contract specifications. The manufacturer's choice of method for factory or field tests on new equipment will govern in lieu of prior agreement or contract specification.

3.3 Use of this standard

After the test method is chosen, all necessary data may be obtained by following the instructions and precautions given in the subclause describing the test. Many of these subclauses include alternate methods for obtaining the necessary data. Unless otherwise specified, the manufacturer may choose the method best suited to the facilities available. It is anticipated that the development of improved practices and new equipment, such as electronic and automatic devices, will result in new or improved methods of carrying out the intent of these test procedures. New or modified methods may be used as substitutes when their results have been shown to be reliable and consistent with those obtained by the methods given in these test procedures.

3.4 Tests with load

Tests with load are made for the determination of efficiency, power factor, speed, current, and temperature rise. Some of the miscellaneous tests outlined in clause 9 are also made with load. For all tests with load, the machine shall be properly aligned and securely fastened. For readings to be used in performance determina-

²IEEE Std 119-1974 has been withdrawn; however, copies can be obtained from Global Engineering, 15 Inverness Way East, Englewood, CO 80112-5704, USA, tel. (303) 792-2181.

³IEEE Std 119-1974 has been withdrawn; however, copies can be obtained from Global Engineering.

⁴The numbers in brackets correspond to those of the bibliography in Annex C.

tions, the machine temperature rise shall be some value between 50% and 100% of rated temperature rise. The usual procedure is to take readings at higher loads first and then follow with readings at lower loads.

3.5 Tests with rotor locked

It should be recognized that the testing of induction machines under locked-rotor conditions with polyphase power involves high mechanical stresses and high rates of heating. Therefore, it is necessary that

- a) The mechanical means of locking the rotor is of adequate strength to prevent possible injury to personnel or damage to equipment.
- b) The direction of rotation is established prior to the test.
- c) The machine is at approximately ambient temperature before the test is started.

The current and torque readings shall be taken as quickly as possible; and, to obtain representative values, the machine temperature should not exceed rated temperature rise plus 40 °C. The readings for any point shall be taken within 5 s after voltage is applied.

3.6 Precautions

Since the performance of an induction machine is dependent not only upon the value of voltage and frequency but also on the wave shape and the balance in magnitude and phase angle of the voltages, correct data can be obtained only by careful measurement and by employing a suitable source of power (see 4.1.2).

CAUTION

Many of the tests described in these procedures subject the machine to thermal and/or mechanical stresses beyond normal operating limits. To minimize the risk of damage to the machine, it is recommended that all tests be performed either under the manufacturer's supervision or in accordance with the manufacturer's recommendations.

4. Measurements

4.1 Electrical

4.1.1 RMS quantities

All voltage and current measurements are rms values, unless otherwise indicated.

4.1.2 Power supply

The power supply shall provide balanced phase voltages closely approaching a sinusoidal waveform. The voltage waveform deviation factor (see note) shall not exceed 10%. The frequency shall be maintained within $\pm 0.5\%$ of the value required for the test being conducted, unless otherwise specified. Any departure from the assumed frequency directly affects the efficiency obtained with methods A and B. When these methods are used, the average frequency shall be within $\pm 0.10\%$ of the specified test value.

NOTE—The deviation factor of a wave is the ratio of the maximum difference between corresponding ordinates of the wave and of equivalent sine wave to the maximum ordinate of the equivalent sine wave when the waves are superposed in such a way as to make this maximum difference as small as possible. The equivalent sine wave is defined as having the same frequency and the same rms value as the wave being tested.

4.1.2.1 Frequency stability

Rapid changes in frequency cannot be tolerated during tests because such variations affect not only the machine being tested, but also the output measuring devices. Variations in frequency during a test shall not exceed 0.33% of the average frequency.

4.1.3 Instrument selection

Calibrated, high-accuracy instrumentation and accessory equipment shall be used. Either analog or digital-type instruments may be used in testing. Factors affecting accuracy, particularly with nonelectronic analog instruments, are

- a) Loading of the signal source
- b) Lead calibration
- c) Range, condition, and calibration of the instrument

Since instrument accuracy is generally expressed as a percentage of full scale, the range of the instrument chosen shall be as low as practical.

The indicating instrument shall bear record of calibration, within 12 months of the test, indicating limits of the error no greater than $\pm 0.5\%$ of full scale for general testing or no greater than $\pm 0.2\%$ of full scale, which is required by Efficiency Test Method B (see 6.4) to maintain accuracy and repeatability of test results. When several instruments are connected in the circuit simultaneously, additional corrections of the instrument indication may be required.

Electronic instruments are generally more versatile and have much higher input impedances than passive (nonelectronic) instruments. Higher input impedance reduces the need to make corrections for the current drawn by the instrument. However, high input impedance instruments are more susceptible to noise.

Common sources of noise are

- a) Inductive or electrostatic coupling of signal leads to power systems
- b) Common impedance coupling or ground loops
- c) Inadequate common mode rejection
- d) Conducted interference from the power line

Good practice requires the use of shielded twisted pairs for signal leads, grounding the shield at only one point, and keeping the signal cables as far away as possible from power cables. All exposed metal parts of these instruments should be grounded for safety.

Instrument calibration requirements are similar to those of nonelectronic instruments. When suitable automatic data acquisition systems or high-speed recorders are available, they may be used. Further information regarding the use of instruments is given in IEEE Std 120-1989.⁵

4.1.4 Instrument transformers

When current and potential instrument transformers are used, corrections shall be made for ratio errors in voltage and current measurements and for ratio and phase angle errors in power measurements.

The errors of the transformers used shall not be greater than 0.5% for general testing or not greater than $\pm 0.3\%$, which is required by Efficiency Test Method B (see 6.4) to maintain accuracy and repeatability of test results. When instrument transformers and instruments for measuring voltage, current, or power are cal-

⁵Information on references can be found in clause 2.

ibrated as a system, the errors of the system shall not be greater than $\pm 0.2\%$ of full scale, which is required by Efficiency Test Method B (see 6.4) to maintain accuracy and repeatability of test results.

4.1.5 Voltage

The line voltages shall be measured with the signal leads connected to the machine terminals. If local conditions will not permit such connections, the error introduced shall be evaluated and the readings shall be corrected. Tests may be performed where the voltage unbalance does not exceed 0.5%. The percent voltage unbalance equals 100 times the maximum voltage deviation from the average voltage divided by the average voltage.

Example: With voltages of 220 V, 215 V, and 210 V, the average voltage is 215 V, the maximum deviation from the average is 5, and the unbalance equals $(100 \times 5)/215 = 2.3\%$.

4.1.6 Current

The line currents to each phase of the motor shall be measured, and the arithmetic average value shall be used in calculating machine performance from the test data.

4.1.7 Power

Power input to a three-phase machine may be measured by two single-phase wattmeters connected as in the two wattmeter method, one polyphase wattmeter, or three single-phase wattmeters methods. Power readings shall be corrected for meter losses if they are significant.

4.2 Resistance

4.2.1 Reference resistance

To obtain dc resistance measurements of stator (and rotor, in the case of wound-rotor machines), the procedures given in IEEE Std 118-1978 should be used.

4.2.2 Reference ambient

All performance determinations should be corrected to an ambient temperature of 25 °C.

4.2.3 Correction to a specified temperature

When the resistance, R_t , of a winding has been determined by test at winding temperature, t_t , the resistance may be corrected to a specified temperature, t_s , by equation 1 as follows:

$$R_s = \frac{R_t(t_s + k)}{(t_t + k)} \quad (1)$$

where

R_s	is the winding resistance, corrected to specified temperature, t_s , in Ω
t_s	is the specified temperature for resistance correction, in °C (see 5.1.1)
R_t	the test value of winding resistance, in Ω , at temperature t_t
t_t	the temperature of winding when resistance was measured, in °C
k	is 234.5 for 100% IACS conductivity copper, or 225 for aluminum, based on a volume conductivity of 62%

NOTES

1—For other winding materials, a suitable value of k (inferred temperature for zero resistance) shall be used.

2—The values for t_s and t_t in equation 1 shall be based on the same method of measurement of temperature, 8.3. The value for t_s in 5.1.1 is based on an average winding temperature, 8.3.3, Method C. When t_t is obtained by direct sensing of local temperature, 8.3.4, Method D, the value for t_t in equation 1 must be adjusted to equal the average temperature of the winding. This can be estimated by assuming a linear relationship between the temperature rise obtained by the two methods.

4.3 Mechanical

4.3.1 Power

Mechanical power measurements shall be taken with the greatest care and accuracy. If a mechanical brake is to be used, the tare, if present, shall be carefully determined and compensated for. If dynamometer output measurements are used, coupling and bearing friction losses must be compensated for. Properly sized dynamometers should be used, such that the coupling, friction, and windage losses of the dynamometer (see the note below) measured at rated speed of the machine being tested should not be greater than 15% of the rated output of the machine being tested; and they should be sensitive to a change of torque of 0.25% of the rated torque.

NOTE—A dynamometer is defined as a device for applying torque to the rotating member of the test machine. It is equipped with means for indicating torque and speed, and is not limited to a cradle base construction. An in-line torque transducer may be used to provide a direct measurement of torque at the test machine shaft.

When required by Efficiency Test Method B to maintain accuracy and repeatability of the test results, the errors of the instrumentation used to measure mechanical torque shall not be greater than $\pm 0.2\%$ of full scale.

When using a dynamometer, the dynamometer shaft power, in watts, is obtained from the following equation:

$$\text{power (in } W) = \omega T = \frac{(T \cdot n)}{k} \quad (2)$$

where

T	is the torque
n	is the rotational speed, in r/min
k	is 9.549, if T is in N · m
k	is 7.043, if T is in lbf · ft

4.3.1.1 Bearing loss stabilization

Some motors may experience a change in friction loss until the bearings reach a stabilized operating condition. In grease lubricated antifriction bearings, stabilization will not occur until there is no excess grease present in the path of the moving parts. This may require a number of hours of running to completely stabilize the no-load input watts. Stabilization can be considered to have occurred whenever the power input at no-load (or coupled to a deenergized dynamometer) does not vary by more than 3% between two successive readings at the same voltage at half-hour intervals.

4.3.2 Speed and slip

4.3.2.1 Instruments

Analog tachometers or speed counters are not sufficiently accurate for the measurement of slip. Therefore, stroboscopic or digital tachometer methods are recommended. When a stroboscope is used, the power supply for the stroboscope should have the same frequency as the motor power supply.

The instrumentation used to measure speed shall not have an error of greater than ± 1.0 r/min of the reading when required by Efficiency Test Method B to maintain accuracy and repeatability of test results.

Slip speed is the difference between synchronous speed and measured speed in r/min, but slip is usually expressed in per unit as

$$s = \frac{\text{slip speed (in r/min)}}{\text{synchronous speed (in r/min)}} \quad (3)$$

4.3.2.2 Slip correction for temperature

Slip measurements should be corrected to the specified stator temperature as follows:

$$S_s = \frac{S_t(t_s + k)}{(t_t + k)} \quad (4)$$

where

- s_s is the slip corrected to specified stator temperature, t_s
- s_t is the slip measured at stator winding temperature, t_t
- t_s is the specified temperature for resistance correction, in °C (see 5.1.1)
- t_t is the observed stator winding temperature during load test, in °C
- k is 234.5 for 100% IACS conductivity copper, or 225 for aluminum, based on a volume conductivity of 62% (based on rotor conductor material)

NOTES:

1—For other rotor winding materials, a suitable value of k (inferred temperature for zero resistance) shall be used.

2—The values for t_s and t_t in equation 1 shall be based on the same method of measurement of temperature, 8.3. The value for t_s , in 5.1.1 is based on an average winding temperature, 8.3.3, Method C. When t_t is obtained by direct sensing of local temperature, 8.3.4, Method D, the value for t_t in equation 1 must be adjusted to equal the average temperature of the winding. This can be estimated by assuming a linear relationship between the temperature rise obtained by the two methods.

4.4 Procedure

Whenever a series of increasing or decreasing readings of data are made, care should be taken in each case not to overrun the desired setting in order to avoid reversing the direction of the test.

4.5 Safety

CAUTION

Because of the dangerous currents, voltages, and forces encountered, safety precautions shall be taken for all tests. No attempt is made here to list or review the manifold general safety precautions that are well established throughout industry. However, this standard includes special safety precautions applicable to the particular tests described. All tests should be performed by knowledgeable and experienced personnel.

5. Types of losses

5.1 Stator I^2R loss

The stator I^2R loss (in watts) is equal to $1.5 I^2R$ for three-phase machines

where

- I is the measured or calculated rms current per line terminal at the specified load
- R is the dc resistance between any two line terminals corrected to the specified temperature (see 4.2.3)

5.1.1 Specified temperature

The specified temperature used in making resistance corrections should be determined by one of the following, which are listed in order of preference:

- a) Measured temperature rise by resistance from a rated load temperature test plus 25 °C (see clause 8). Rated load is the rating identified on the nameplate at 1.0 service factor.
- b) Measured temperature rise on a duplicate machine as outlined in a).

NOTE—A duplicate machine shall be one of the same construction and electrical design.

- c) When the rated load temperature rise has not been measured, the resistance of the windings should be corrected to the temperature shown in table 1.

Table 1—Specified temperature

Class of insulation system	Temperature in °C
A	75
B	95
F	115
H	130

This reference temperature should be used for determining I^2R losses at all loads. If the rated temperature rise is specified as that of a lower class of insulation system than that used in the construction, the temperature for resistance correction should be that of the lower insulation class.

5.2 Rotor I^2R loss

The rotor I^2R loss, including brush-contact losses for wound-rotor machines, should be determined from the per unit slip, whenever the slip is accurately determinable, using equations 5 and 6 as follows:

$$\text{motor rotor } I^2R \text{ loss} = (\text{measured stator input power} - \text{stator } I^2R \text{ loss} - \text{core loss}) \cdot s \quad (5)$$

$$\text{generator rotor } I^2R = (\text{measured stator output power} + \text{stator } I^2R \text{ loss} + \text{core loss}) \cdot s \quad (6)$$

5.3 Core loss and friction and windage loss (no-load test)

The test is made by running the machine as a motor at rated voltage and frequency without connected load. To ensure that the correct value of friction loss is obtained, the machine should be operated until the input has stabilized (see 4.3.1.1).

5.3.1 No-load current

The current in each line is read. The average of the line currents is the no-load current.

5.3.2 No-load losses

The reading of input power is the total of the losses in the motor at no-load. Subtracting the stator I^2R loss (at the temperature of this test) from the input gives the sum of the friction (including brush-friction loss on wound-rotor motors), windage, and core losses.

5.3.3 Separation of core loss from friction and windage loss

Separation of the core loss from the friction and windage loss may be made by reading voltage, current, and power input at rated frequency and at voltages ranging from 125% of rated voltage down to the point where further voltage reduction increases the current.

5.3.4 Friction and windage

Power input minus the stator I^2R loss is plotted vs. voltage, and the curve so obtained is extended to zero voltage. The intercept with the zero voltage axis is the friction and windage loss. The intercept may be determined more accurately if the input minus stator I^2R loss is plotted against the voltage squared for values in the lower voltage range. An example is the dashed curve shown in figure 1.

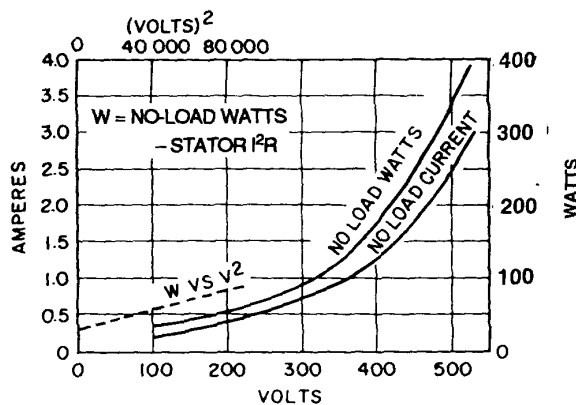

Figure 1—Determination of friction and windage losses

5.3.5 Core loss

The core loss at no load and rated voltage is obtained by subtracting the value of friction and windage loss (obtained from 5.3.4) from the sum of the friction, windage loss, and core loss (obtained from 5.3.2).

5.4 Stray-load loss

The stray-load loss is that portion of the total loss in a machine not accounted for by the sum of friction and windage, stator I^2R loss, rotor I^2R loss, and core loss.

5.4.1 Indirect measurement

The stray-load loss is determined by measuring the total losses, and subtracting from these losses the sum of the friction and windage, core loss, stator I^2R loss, and rotor I^2R loss. Indirect measurement is used in efficiency methods B, C, and C/F (see 6.4, 6.5, and 6.8).

- The procedure for determining the stray-load loss (Method B) is described in 6.4.2.6.
- The procedure for determining the stray-load loss (Method C) is described in 6.5.2.
- The procedure for determining the stray-load loss (Method C/F) is described in 6.8.1.

5.4.2 Direct measurement

Direct measurement is used in efficiency methods E, F, and E/F (see 6.6, 6.7, and 6.8).

5.4.2.1 Stator component in stray-load loss

The stray-load loss occurring at fundamental frequency is determined by applying balanced polyphase voltage to the stator-winding terminals with the rotor removed. The electrical input minus the stator I^2R loss at test temperature is equal to the fundamental frequency stray-load loss. During this test, bearing brackets and other structural parts in which current might be induced shall be in place. The currents used in making this

test and that described in 5.4.2.2 should be identified as I_t and should have values established by equation 7 for magnitudes covering the range of loads from 1/4 to 1-1/2 times rated load, as indicated by the appropriate test procedure.

$$I_t = \sqrt{(I^2 - I_0^2)} \quad (7)$$

where

- I_t is the value of stator winding current during stray-load loss test
- I_0 is the value of no-load current (see 5.3.1)
- I is the operating value of stator line current for which stray-load loss is to be determined

5.4.2.2 Reverse rotation test procedure

The stray-load loss occurring at high frequencies is determined by a reverse rotation test. With the motor completely assembled, balanced polyphase voltage at rated frequency is applied at the stator winding terminals. The rotor is driven by external means at synchronous speed in the direction opposite to the stator field rotation. (The correct speed may be determined easily by stroboscopic methods or by a digital tachometer.) The electrical input to the stator winding is measured.

The mechanical power required to drive the rotor is measured both with and without current in the stator winding. The current magnitude shall be the same values as used in 5.4.2.1. For wound-rotor motors, the rotor terminals shall be short circuited.

5.4.2.3 Stray-load loss calculation for direct method

The stray-load loss, W_{LL} , is calculated as follows:

$$W_{LL} = LL_s + LL_r \quad (8)$$

In equation 8, the values of LL_s and LL_r are calculated for the same values of line currents I_t

where

$$LL_s = W_s - \text{stator winding } I^2R \text{ loss} = \text{fundamental frequency stray-load loss}$$

The stator winding I^2R loss shall be the product of the number of phases, I_t^2R and r_1 , taken at each load point.

$$LL_r = (P_r - P_f) - (W_r - LL_s - \text{stator winding } I^2R \text{ loss}) = \text{higher frequencies stray-load loss}$$

The stator winding I^2R loss shall be the product of the number of phases, I_t^2R and r_1 , taken at each load point.

- r_1 is the stator phase resistance (for a three-phase machine, this is taken as one-half of the resistance between terminals)
- P_r is the mechanical power required to drive rotor with voltage applied at stator winding terminals
- P_f is the mechanical power required to drive rotor without voltage being applied at stator winding terminals

- W_s is the electrical input to stator winding with rotor removed
 W_r is the electrical input to stator winding during reverse-rotation test

5.4.2.4 Smoothing of test data

Smooth the test values of $(P_r - P_f)$, W_s , and W_r by using a regression analysis of the log of the power vs. the log of the current. Then,

$$(P_r - P_f) = A_1(I_t)^{N1} \quad (9)$$

$$W_s = A_2(I_t)^{N2} \quad (10)$$

$$W_r = A_3(I_t)^{N3} \quad (11)$$

where

- A is the y intercept on a log-log plot (a constant)
 N is the slope on a log-log plot (approximately 2)
 I is the observed line current during the stray-load loss test

If the data are accurate, each curve will conform to a square-law relationship between power and current. Thus, the correlation factor from the regression and exponent for each curve both serve as indicators of data accuracy.

NOTE—The low power factors encountered during the tests specified in 5.4.2.1 and 5.4.2.2 make it imperative that phase-error corrections be applied to all wattmeter readings. Refer to IEEE Std 120-1989.

5.4.2.5 Calculating stray-load loss at a specified point

(1) Determine an approximate value of rotor current I_2' corresponding to the rated value of stator line current, I , as

$$I_2' = (I^2 - I_o^2)^{1/2} \quad (12)$$

where

- I is the rated value of stator line current
 I_o is the value of no-load stator current

(2) For the value of rotor current I_2' , calculate a value of stray-load loss W'_{LL} for three-phase machines as follows:

$$W'_{LL} = A_1 \times (I_2')^{N1} + 2A_2 \times (I_2')^{N2} - A_3 \times (I_2')^{N3} - 3 \times (I_2')^2 \times (2 \times r_{1s} - r_{1r}) \quad (13)$$

where

- W'_{LL} is the value of stray-load loss for approximate value of rotor current corresponding to rated load
 I_2' is the approximate value of rotor current corresponding to rated load from equation 12

- r_{1s} is the stator resistance per phase during rotor removed test at test temperature (see 5.4.2.1)
 r_{1r} is the stator resistance per phase during reverse rotation test at test temperature (see 5.4.2.2)

The value of stray-load loss, W_{LL} , reported in 10.4 or 10.6, corresponds to a value of I_2' as calculated using equation 12.

(3) The value of stray-load loss, W_{LL} , for any load point, is then calculated as

$$W_{LL} = W'_{LL} \cdot \left(\frac{I_2}{I_2'} \right)^2 \quad (14)$$

where

- I_2 is the value of rotor current appropriate to the load point for which stray-load loss is to be determined

(4) The value of rotor current is calculated as

$$I_2 = \sqrt{(I^2 - I_0^2)} \text{ or } (I^2 - I_0^2)^{\frac{1}{2}} \quad (15)$$

where

- I is the operating value of stator line current for which stray-load loss is to be determined
 I_0 is the value of no-load current

5.4.3 Alternate direct method for wound-rotor motors

This method is used with efficiency methods E, F, and E/F (see 6.6, 6.7, and 6.8). In this method, the rotor is excited with direct current, and the stator winding terminals are short-circuited with ammeters included to read the stator current. The rotor is driven by external means at synchronous speed. The rotor excitation is adjusted until the current circulating in the stator winding has the value for which a stray-load loss determination is desired. The mechanical power required to drive the rotor, with excitation, (P_r), and without excitation, (P_f), is measured.

$$W_{LL} = P_r - P_f - \text{stator winding } I^2R \text{ loss at temperature during test} \quad (16)$$

If six load points are used, the accuracy can be improved by plotting stray-load loss vs. stator winding current squared and by following a smoothing procedure similar to 5.4.2.4.

5.4.4 Assumed stray-load loss

This measurement is used with efficiency methods E1, F1, and E1/F1 (see 6.6, 6.7, and 6.8). If the stray-load loss is not measured, and it is acceptable by applicable standards or by contract specifications, the value of stray-load loss at rated load may be assumed to be the value shown in Table 2.

Table 2—Assumed values for stray-load loss

Machine rating		Stray-load loss percent of rated output
1–125 hp	1–90 kW	1.8%
126–500 hp	91–375 kW	1.5%
501–2499 hp	376–1850 kW	1.2%
2500 hp and greater	1851 kW and greater	0.9%

For other than rated load, it shall be assumed that the stray-load loss, W_{LL} , is proportional to the square of the rotor current, i.e.,

$$W_{LL} = W'_{LL} \left(\frac{I_2}{I_2'} \right)^2 \quad (17)$$

where

W'_{LL} is the value of stray-load loss corresponding to a value of rotor current I_2'

I_2 is the value of rotor current appropriate to the load point for which stray-load loss is to be determined

I_2' is the value of rotor current corresponding to rated load

5.5 Brush-contact loss

This measurement is used in efficiency methods F and F1 (see 6.7). For wound-rotor machines, the brush-contact loss should be determined by the product of the calculated secondary current and a voltage drop. The voltage drop in all brushes of the same phase (between rings on a three-ring machine) may be assumed to be 1.0 V for carbon or graphite brushes, and 0.3 V for metal-carbon brushes.

6. Determination of efficiency

6.1 General

Efficiency is the ratio of output power to total input power. Output power is equal to input power minus the losses. Therefore, if two of the three variables (output, input, or losses) are known, the efficiency can be determined by one of the following equations:

$$\text{efficiency} = \frac{\text{output power}}{\text{input power}} \quad (18)$$

$$\text{efficiency} = \frac{\text{input power} - \text{losses}}{\text{input power}} \quad (19)$$

(Particularly applicable to motors)

$$\text{efficiency} = \frac{\text{output power}}{\text{output power} + \text{losses}} \quad (20)$$

(Particularly applicable to generators)

Unless otherwise specified, the efficiency should be determined for rated voltage and frequency. Efficiency can be determined most accurately from the test results when the voltage does not deviate significantly from rated voltage and the voltage unbalance does not exceed 0.5% (see 4.1.5). When a load point is available at other than rated voltage, it may be combined with the equivalent circuit (Methods F and F1) to calculate the performance at rated voltage (see 6.8).

6.2 Test methods for efficiency

The various methods of efficiency and loss determination are identified as follows:

- a) *Method A*. Input-output
- b) *Method B*. Input-output with segregation of losses and indirect measurement of stray-load loss
- c) *Method C*. Duplicate machines with segregation of losses and indirect measurement of stray-load loss
- d) *Method E*. Electric power measurement under load with segregation of losses and direct measurement of stray-load loss
- e) *Method E1*. Electric power measurement under load with segregation of losses and assumed value of stray-load loss
- f) *Method F*. Equivalent circuit with direct measurement of stray-load loss
- g) *Method F1*. Equivalent circuit with assumed value of stray-load loss
- h) *Method C/F*. Equivalent circuit calibrated per Method C load point with indirect measurement of stray-load loss
- i) *Method E/F*. Equivalent circuit calibrated per Method E load point with direct measurement of stray-load loss
- j) *Method E1/F1*. Equivalent circuit calibrated per Method E load point with assumed value of stray-load loss

6.2.1 Guide for choice of efficiency test method

In general, the input-output method (Method A) should be limited to fractional-horsepower machines. Unless otherwise specified, horizontal, polyphase, squirrel-cage motors rated 1–250 hp (1–190 kW) should be tested by the input-output method with loss segregation (Method B). Method B should be selected when the value for each of the components of the loss in the motor (see clause 5) is desired or when the precision and repeatability of this method is required, for example by the EEM Program [B4]. Vertical motors in the range of 1–250 hp (1–190 kW) should also be tested by Method B, if bearing construction permits. If the bearing construction does not permit, vertical motors in this horsepower range may be tested by Method E, E1, F, or F1. Polyphase motors larger than 250 hp (190 kW) may be tested by Method B, C, E, E1, F, or F1 depending on the availability of the required test facility. When practical, load calibration of the equivalent circuit (Method C/F, E/F, or E1/F1) provides the confidence level of a test with the simplicity of determining performance at various loads by solution of the equivalent circuit.

6.3 Test Method A—Input-output

For this method, the efficiency is calculated as the ratio of the measured output power to the measured input power, after temperature and dynamometer correction (if applicable).

6.3.1 Test procedure

The machine is loaded by means of a mechanical brake or dynamometer (see 4.3.1).

Readings of electrical power, current, voltage, frequency, slip, torque, ambient temperature, and stator winding temperature or stator winding resistance shall be obtained for four load points approximately equally spaced between not less than 25% and up to and including 100% load, and two load points suitably chosen above 100% load but not exceeding 150% load. In loading the machine, start at the highest load value and move in descending order to the lowest.

6.3.2 Calculation form

Performance is calculated as shown in Form A in 10.1. Dynamometer correction should be made, if applicable, as outlined on the form. The stator I^2R loss is to be corrected for temperature as indicated.

NOTE—The dynamometer correction should be made with the same direction of rotation that is used during the load test.

6.4 Test Method B—Input-output with loss segregation

This method consists of several steps. All data are taken with the machine operating either as a motor or as a generator, depending upon the region of operation for which the efficiency data is required. The apparent total loss (input minus output) is segregated into its various components with stray-load loss defined as the difference between the apparent total loss and the sum of the conventional losses (stator and rotor I^2R loss, core loss, and friction and windage loss). The value of stray-load loss thus determined is plotted vs. torque squared, and a linear regression is used to reduce the effect of random errors in the test measurements. The smoothed stray-load loss data are used to calculate the final value of total loss and the efficiency.

To minimize the differences in the value of total loss and the value of efficiency when determined by tests performed at different facilities, the accuracy of the instrumentation used to make the electrical power, torque, and speed measurements shall be greater than that required for general testing with any of the other test methods (see clause 4). This is particularly important when testing is being made to meet the requirements for energy efficiency [B3], [B4].

6.4.1 Test procedure

The subtests that make up the Method B test procedure are to be performed in the order listed. It is not necessary that the subtests be performed in time succession with each immediately following the previous one. The subtests can be performed individually if the operating temperature of the motor is established close to its normal rated load operating temperature for the type of test prior to obtaining the test data.

6.4.1.1 Rated load temperature test

The machine is coupled to a dynamometer and operated at rated load as defined in 8.6 until thermally stable. This test is not required when a rated load temperature test had previously been performed on a duplicate machine.

6.4.1.2 Test under load

The machine is loaded by a dynamometer, see 4.3.1. The temperature of the stator winding shall be within 10 °C of the hottest temperature reading recorded during the rated load temperature test on this or the duplicate machine prior to the start of recording data for this test. The test procedure of 6.3.1 is used, the test

being performed as quickly as possible to minimize temperature changes in the machine during testing. A dynamometer correction shall be made as outlined in 10.2.

NOTE—The dynamometer correction should be made with the same direction of rotation that is used during the load test.

6.4.1.3 No-load test

See 5.3 including 5.3.3, the separation of core loss from friction and windage loss. Prior to making this test, the machine shall be operated at no-load until both the temperature and the input have stabilized.

6.4.2 Calculation form

Calculate motor or generator performance using Form B in 10.2, which includes temperature correction and the segregation of the losses. The value for the stray-load loss is determined by the indirect method.

6.4.2.1 Friction and windage loss

See 5.3.4.

6.4.2.2 Core loss

See 5.3.5.

6.4.2.3 Stator I^2R loss

See 5.1.

If the stator resistance is not directly measured during the test, the resistance for each load point shall be determined as in 4.2.3 with the value for the specified temperature set to that of the temperature measured during the test at each load point.

6.4.2.4 Rotor I^2R loss

See 5.2.

6.4.2.5 Apparent total loss

The apparent total loss shall be calculated separately for each load point by subtracting the measured output in watts from the measured input in watts.

6.4.2.6 Stray-load loss determination (indirect method)

The stray-load loss shall be separately calculated for each load point by subtracting from the apparent total loss the stator I^2R loss at the temperature of the test, the core loss, the friction and windage loss, and the rotor I^2R loss corresponding to the measured value of slip. The stray-load loss shall be calculated for each of the six approximately equally-spaced load points (see 6.3.1).

6.4.2.7 Smoothing of the stray-load loss

Smooth stray-load loss data by using a linear regression analysis based on expressing the stray-load loss as a function of the square of the load torque as detailed in 10.2, Form B.

$$W_{LL} = AT^2 + B \quad (21)$$

where

W_{LL} is the stray-load loss as plotted vs. torque squared

T is the torque

A is the slope

B is the intercept with the zero torque line

If the slope is negative, or if the correlation factor, r , is less than 0.9, delete the worst point and repeat the regression. If this increases r to 0.9 or larger, use the second regression; if not, or if the slope is still negative, the test is unsatisfactory. Errors in the instrumentation or test readings, or both, are indicated. The source of the error should be investigated and corrected, and the test should be repeated.

Dynamometer bearing friction or measurement errors, or both, may cause torque readings to differ for the same value of electrical power, depending upon whether the load is increasing or decreasing prior to reading. When a correlation factor, r , less than 0.9 is obtained after the second calculation, the average of two sets of readings should be taken. The first set should be taken while gradually increasing the load, the second set while decreasing load. Curves of torque vs. electrical power should be plotted for each set of readings, and the average value of A based on the two curves should be used.⁶

6.4.3 Correction of total loss and efficiency

6.4.3.1 Corrected stray-load loss

The corrected value of stray-load loss is

$$W_{LLC} = AT^2 \quad (22)$$

6.4.3.2 Ambient temperature correction of stator I^2R loss

A corrected stator I^2R loss for each of the six load points is calculated using the common value of stator resistance obtained from the rated load temperature test corrected to an ambient of 25 °C. In 4.2.3, the resistance R_t is the measured resistance at the conclusion of the rated load temperature test; t_t is the hottest winding temperature measured during the temperature test, and t_s is equal to t_t corrected to an ambient of 25 °C.

6.4.3.3 Ambient temperature correction of rotor I^2R loss

A corrected rotor I^2R loss for each of the six load points is calculated as in 5.2 using the value of slip for each of the points corrected to an ambient of 25 °C and using the ambient corrected value of the stator I^2R loss for each load point. In 4.3.2.2, the slip s_t is the measured slip for the particular load point, t_t is the hottest winding temperature measured for the particular point; and t_s is the hottest winding temperature during the temperature test corrected to an ambient of 25 °C.

⁶It may be desirable to make a check test by operating the machine as a generator and the dynamometer as a motor, if possible. Errors in scales or instruments will occur in opposite directions during the two tests, but the errors will tend to cancel in the average, even though the individual errors may be large. The total losses will be equal to the mechanical input minus the electrical output for generating action, or they will be equal to the electrical input minus the mechanical output for motoring action. The residual loss (apparent total loss minus conventional loss) shall be separately calculated for each case (motoring and generating) using the procedure in 6.4.2.6 for six approximately equally-spaced load points (see 6.3.1). Smooth the residual loss for each case (motoring and generating) using the procedure in 6.4.2.7. The stray-load loss is taken as the average of the motoring and generating value appropriate to the load point, i.e., using a tachometer to ± 0.1 r/min in order to achieve the required correlation factor.

6.4.3.4 Corrected total loss

A corrected total loss for each of the six load points is determined as the sum of the friction and windage loss (see 6.4.2.1), the core loss (see 6.4.2.2), the corrected stray-load loss (see 6.4.3.1), the temperature corrected stator I^2R loss (see 6.4.3.2), and the temperature corrected rotor I^2R loss (see 6.4.3.3).

6.4.3.5 Corrected mechanical power

The corrected mechanical power for each of the six load points is equal to the difference between the measured input power and the corrected total loss for a motor. The corrected input power is equal to the sum of the output power and the sum of the corrected total loss for a generator.

6.4.3.6 Efficiency

See 6.1. Use the measured electrical power and the corrected mechanical power from 6.4.3.5.

6.4.4 Motor/generator performance

Calculate motor or generator performance using 10.2, which includes temperature correction.

6.5 Test Method C—Duplicate machines

This method of determining efficiency may be used when duplicate machines are available. The two machines are coupled together and electrically connected to two sources of power, the frequency of one being adjustable.

6.5.1 Test procedure

6.5.1.1 No-load tests of both machines

See 5.3.

6.5.1.2 Test under load

One machine is operated as a motor at rated voltage and frequency, and the other is driven as a generator at rated voltage per hertz, but at lower frequency, to produce the desired load. Readings should be taken of the electrical input and output, stator winding temperature or stator winding resistance, and slip of each machine.⁷

The test should be repeated with the direction of power flow reversed. The frequency of the first machine remains unchanged while that of the second is raised to produce the desired load. The location of the instruments and instrument transformers are not to be changed. By this reversal of power flow, ordinary calibration errors of all instruments are minimized. Phase angle errors of the instrument transformers are cumulative for motoring and generating tests. It is important to make accurate corrections for the phase angle errors, because they will make the losses appear smaller than the true value (see 4.1.4).

6.5.2 Stray-load loss (indirect method)

The stray-load loss is obtained as follows:

⁷These values shall be obtained for four load points approximately equally spaced between not less than 25% load and up to and including 100% load, and two load points suitably chosen above 100% load but not exceeding 150% load. Alternatively, a single load point may be combined with Method F to determine performance at other load points. See 6.8.

- 1) The stator I^2R loss at the temperature of the test is calculated for each machine using the observed currents.
- 2) The motor rotor I^2R loss is

$$\text{motor slip} \cdot (\text{motor input} - \text{stator } I^2R \text{ loss} - \text{core loss}) \quad (23)$$

using the observed motor slip in per unit of synchronous speed.

- 3) The generator rotor I^2R loss is

$$\text{generator slip} \cdot (\text{generator output} + \text{stator } I^2R \text{ loss} + \text{core loss}) \quad (24)$$

using the observed generator slip in per unit of synchronous speed.

- 4) The combined stray-load loss is determined by subtracting from the total measured loss (the difference between input and output) the sum of the stator I^2R losses, rotor I^2R losses, core losses, and friction and windage losses of the two machines.
- 5) The stray-load losses are assumed to be proportional to the square of the rotor current. The stray-load losses are taken as

$$\text{motor stray-load loss} = \text{motor rotor } I^2R \text{ loss} \cdot \frac{\text{combined stray-load loss}}{\text{motor rotor } I^2R \text{ loss} + \text{generator rotor } I^2R \text{ loss}}$$

$$\text{generator stray-load loss} = (\text{combined stray-load loss}) - (\text{motor stray-load loss})$$

The average of the results obtained with the two directions of power flow (motoring and generating) is taken as the average value of stray-load loss.

6.5.2.1 Smooth stray-load loss data by using a linear regression analysis

$$W_{LLave} = A(I_{2ave})^2 + B \quad (25)$$

where

- W_{LLave} is the average value of stray-load loss as plotted vs. approximate rotor current squared
- A is the slope
- B is the intercept with the zero current line
- I_{2ave} is the average value of rotor current

The value of rotor current, I_2 , for each direction of power flow (motoring and generating) is taken as

$$I_2 = \sqrt{(I^2 - I_0^2)} \quad (26)$$

where

- I is the observed value of stator line current (motoring or generating) for which stray-load loss is to be determined
- I_0 is the value of no-load current

The corrected value of stray-load loss is

$$W_{LLc} = A(I_2)^2 \quad (27)$$

6.5.3 Motor/generator performance

Calculate motor or generator performance using Form C in 10.3, which includes temperature correction. Determine W_{LLc} based on the slope, A , and the value of rotor current, I_2 , appropriate to the load point for which stray-load loss is to be determined.

The value of rotor current for each load point is calculated as

$$I_2 = \sqrt{(I^2 - I_0^2)} \quad (28)$$

where

- I is the operating value of stator line current for which stray-load loss is to be determined
- I_0 is the value of no-load current

6.6 Test method E or E1—Electrical power measurement with loss segregation

The input should be measured as outlined below. The output should be determined by subtracting the total losses from the input. The total losses equal the sum of the stator and rotor I^2R losses corrected to the specified temperature for resistance correction, core loss, friction and windage loss, and stray-load loss.

6.6.1 Test procedure

6.6.1.1 No-load test

See 5.3.

6.6.1.2 Test under load

To obtain the required data, it is necessary to couple, belt, or gear the machine to a variable load. The same arrangement that is used for the temperature test may be employed. For each of six approximately equally-spaced points, the readings of electrical power, current, voltage, slip, ambient temperature, and stator winding resistance or temperature are to be recorded (see Footnote 5). The stator winding resistance for each load point can be estimated by comparing the temperature rise measured by an embedded temperature detector, a temperature sensor located on the stator coil end, or the air outlet temperature rise, with corresponding temperature rise measurements obtained as steady-state values during a temperature test.

6.6.1.3 Stray-load loss test

6.6.1.3.1 Test Method E

See 5.4.2 or 5.4.3.

6.6.1.3.2 Test Method E1

See 5.4.4.

6.6.2 Stator I^2R losses

See 5.1.

6.6.3 Rotor I^2R losses

See 5.2.

6.6.4 Core loss

See 5.3.5.

6.6.5 Friction and windage

See 5.3.4.

6.6.6 Stray-load loss (direct measurement)

6.6.6.1 Rotor current I^2

The value of rotor current shall be calculated as

$$I_2 = \sqrt{(I^2 - I_0^2)} \quad (29)$$

where

- I is the operating value of stator line current for which stray-load loss is to be determined
- I_0 is the value of no-load current

The value of stray-load loss, W'_{LL} , reported in 10.4 shall correspond to a value of rotor current, I_2' , as calculated from equation 29 for a value of I corresponding to the rated value of stator line current.

6.6.7 Motor/generator performance

Calculate motor or generator performance using 10.4, which includes temperature correction.

6.7 Test Method F or F1—Equivalent circuit

When tests under load are not made, operating characteristics (efficiency, power factor, torque, etc.) are calculated based upon the equivalent circuit shown in figure 2. The machine parameters in the equivalent circuit are derived from test data recorded during a no-load test and an impedance test. Accurate prediction of machine characteristics in the normal operating range will depend primarily upon the closeness by which r_2 represents the actual rotor resistance to currents of low frequency and, secondarily, upon the closeness by which x_2 represents the actual rotor leakage reactance to currents of low frequency. Therefore, the most careful procedure during testing to determine the rotor characteristics at low frequency is imperative.

6.7.1 Test procedure

6.7.1.1 No-load test

See 5.3.

6.7.1.2 Impedance test

Readings of voltage, current, electrical input power, and stator resistance or stator winding temperature are to be taken at one or more frequencies, voltages, and/or loads. This data is referred to as the impedance data. If the machine being tested has a wound rotor, the rotor is to be short-circuited for the test.

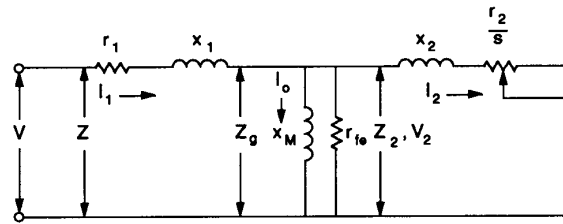

Figure 2—Equivalent circuit

The reactance shall be measured at rated load current. It is important that the value of reactance used in the equivalent circuit calculation is at the correct value of saturation and deep bar effect; otherwise, the calculated power factor will be found to be higher than the true value.

The impedance data shall be determined from one of the following methods:⁸

- Method 1 Three-phase locked-rotor impedance test at maximum of 25% of rated frequency and at rated current.⁹ See 6.7.1.2.1 for details.
- Method 2 Three-phase locked-rotor impedance test at rated frequency, at approximately 50% of rated frequency, and at a maximum of 25% of rated frequency, all at rated current. Curves shall be developed from these three test points and used to determine the values of total reactance and rotor resistance at the required reduced frequency.¹⁰ See 6.7.1.2.1 for details.
- Method 3 An impedance test above the speed of the breakdown point at a slip speed approximating the desired reduced rotor frequency. In this method, the motor is run uncoupled or coupled to a reduced load, and the voltage is reduced to give approximately full load slip point. The slip shall be measured carefully. See 6.7.1.2.2 for details.
- Method 4 When none of the above methods is practical, the following test may be utilized: a three-phase, locked-rotor impedance test at reduced voltage at rated frequency resulting in approximately rated current and a test under load. See 6.7.1.2.3 for details.

6.7.1.2.1 Locked-rotor tests (Method 1 and Method 2)

The rotor of a squirrel-cage motor is a symmetrical bar winding; therefore, the impedance of the motor is practically the same for any position of the rotor relative to the stator.

The impedance of a wound-rotor motor varies with the position of the rotor relative to the stator. It is therefore necessary when performing a locked-rotor impedance test to determine the rotor position that results in an average value of impedance. Before taking readings on wound-rotor machines, the rotor shall be short-

⁸The impedance is thus determined at the temperature of the motor at the time of the test.

⁹The total reactance of the machine for use in the performance calculation by 10.5, Method F, is computed from the reactance determined at reduced frequency by multiplying the low-frequency value by the ratio of rated frequency to the low frequency. In general, the reactance so determined will be larger than when directly measured at normal frequency, the difference being small for single squirrel-cage rotors and relatively large for double squirrel-cage or deep bar rotors.

¹⁰See Footnote 7.

circuited. The angular distance through which it is necessary to observe the current variation shall be determined by allowing the rotor to revolve slowly and observing the stator current, noting the distance the rotor must move for the stator current to complete a cycle. For machines having an integral number of slots per pole per phase in both rotor and stator, this distance will be equal to two-thirds of a pole pitch for three-phase machines. For machines having fractional slot windings, the angular distance may be as much as a full pole pitch.

The rotor shall be blocked so that it cannot move; and the impressed voltage shall be increased gradually until a current of approximately rated value is obtained. Voltage and current on all phases shall be read and recorded, and the voltage in the different phases shall be balanced. Holding the same voltage, the rotor shall be turned slowly and the minimum and maximum values of current during a complete cycle shall be recorded. The rotor shall then be blocked for the impedance test on the position that gives a current equal to the average of the minimum and maximum values previously recorded.

- a) Take simultaneous readings of voltage and current in all phases and of power input at several levels of voltage in order to establish the value with special care in the neighborhood of full-load current. The stator winding temperature or stator winding resistance shall also be recorded. Care shall be taken not to overheat the windings. Taking the highest readings first and the lower readings in succession will help to equalize the temperature.
- b) Plot curves using volts as abscissas and amperes and the algebraic sum of the watt-meter readings as ordinates. The curve of amperes vs. volts is usually a straight line, curving slightly upward at the higher values. On closed slot rotors, however, there is also a distinct curve upward at low voltage. Derive the value of voltage and power input to determine the total reactance and rotor resistance at the required level of current from these curves.
- c) Determine the rotor resistance, r_2 , and the total leakage reactance, $X_1 + X_2$, from these data using the equations of 10.5. When using Method 2 in 6.7.1.2, curves of the values of rotor resistance and total leakage reactance vs. frequency should be used to determine the value at the desired operating frequency.

6.7.1.2.2 Impedance from reduced-voltage, reduced-load running test (Method 3)

The rotor resistance, r_2 , and the leakage reactance, X_2 , at reduced frequency may be obtained from readings (volts, watts, amperes, slip, stator winding temperature, or stator winding resistance) at a slip speed approximating the desired reduced rotor frequency. In this method, the machine is run uncoupled or coupled to a reduced load and at a voltage that gives the desired slip speed. The slip shall be measured very carefully. The following procedure is used.

When data from the no-load saturation test is available (see 5.3), the total reactance per phase for each test point should be calculated and a curve of total reactance per phase vs. no-load volts per phase should be drawn (see example in figure 3). The highest point on this curve should be used as the total no-load reactance per phase, $X_1 + X_m$, in calculations of the low-voltage slip test.

When a complete no-load test has not been performed, the total reactance per phase at rated voltage and no load can be used as the total no-load reactance per phase, $X_1 + X_m$, in calculations of the low-voltage slip test.

From the low-voltage slip test data, calculate the impedance per phase, Z , the resistance per phase, R , and the reactance per phase, X .

Also calculate $\cos\theta_1 = R/Z$, and $\sin\theta_1 = X/Z$.

If the design details are available, use the calculated ratio $\frac{X_1}{X_2}$. Otherwise use the ratios given on Form F-1 (see 10.5).

$$X_1 = X \cdot \frac{X_1/X_2}{1 + X_1/X_2} \quad (30)$$

Using the value of total no-load reactance, $X_1 + X_m$, determined above, the value of the magnetizing reactance, X_m , can be approximated as

$$X_m = (X_1 + X_m) - X_1 \quad (31)$$

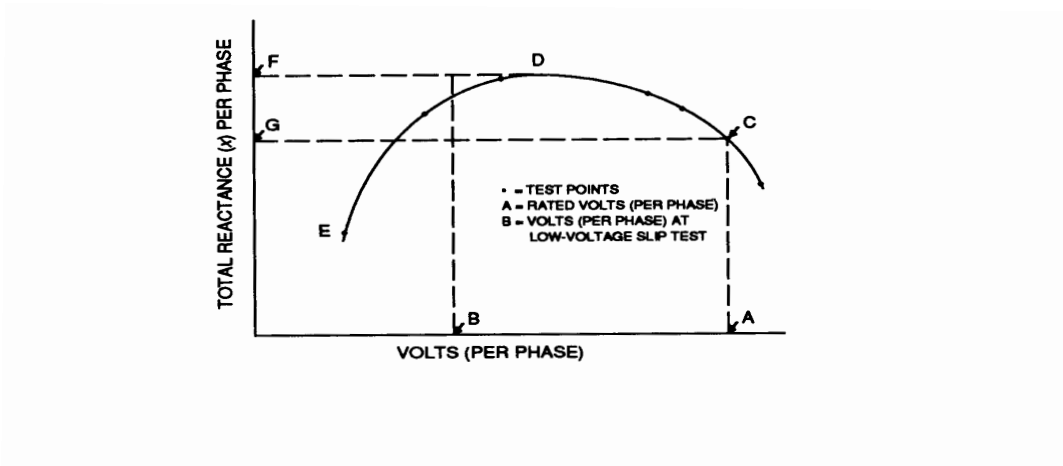

- A is rated volts
- B is the volts at low-voltage slip test
- CDE is the curve of total reactance from no-load test
- F is the reactance corresponding to the highest point, D , of the test curve CDE . This value is used as the total reactance, $X_1 + X_m$, in calculations of the low-voltage slip test
- G is the total reactance, $X_1 + X_m$, to be used in determining X_m for use in the equivalent circuit calculations after X_1 , X_2 , and R_2 are determined from the calculations of the low-voltage slip test

Figure 3—Total reactance from no-load test

From the data obtained from the low-voltage slip test, calculate

$$V_2 = \{ [V_1 - I_1 X_1 \sin \theta_1 \pm R_1 \cos \theta_1]^2 + [I_1 X_1 \cos \theta_1 \pm R_1 \sin \theta_1]^2 \} \quad (32)$$

$$\theta_2 = \arctan \frac{I_1 (X_1 \cos \theta_1 \pm R_1 \sin \theta_1)}{V_1 - I_1 (X_1 \sin \theta_1 \pm R_1 \cos \theta_1)} \quad (33)$$

$$I_e = \frac{V_2}{X_m} \quad (34)$$

$$r_{fe} = \frac{(V_2^2)}{\left(\frac{W_n}{m}\right)} \quad (35)$$

$$g_{fe} = \frac{1}{r_{fe}} \quad (36)$$

$$I_{fe} = \frac{\left(\frac{W_n}{m}\right)}{V_2} \quad (37)$$

Calculate

$$I_2 = [(I_1 \cos \theta_1 + I_e \sin \theta_2 m I_{fe} \cos \theta_2)^2 + (I_1 \sin \theta_1 - I_e \cos \theta_2 \pm I_{fe} \sin \theta_2)^2]^{1/2} \quad (38)$$

NOTES

1—For induction generator, use alternate (lower) sign in equations 32, 33, 38, and 47.

2—Correct R_1 to the temperature during test.

3— $\cos \theta_1$ equals power factor during motoring or generating test.

$$X_2 = \frac{V_1 I_1 \sin \theta_1 - I_1^2 X_1 - I_0 V_2}{I_2^2} \quad (39)$$

$$X = X_1 + X_2 \quad (40)$$

Repeat equations 30 through 40 using the initial ratio of X_1/X_2 from equation 30 and the new value of X from equation 40 until stable values for X_1 and X_2 are achieved within 0.1%.

$$X_1 = X \cdot \frac{X_1/X_2}{1 + X_1/X_2} \quad (41)$$

$$X_2 = X - X_1 \quad (42)$$

$$Z_2 = \frac{V_2}{I_2} \quad (43)$$

$$R_2 = s \cdot \sqrt{Z_2^2 - X_2^2} \quad (44)$$

Then, from the rated voltage no-load test point, calculate

$$X_m = X - X_1 \quad (45)$$

$$-b_m = \frac{1}{X_m} \quad (46)$$

$$V_2 = \{[V_1 - I_1(X_1 \sin \theta_1 \pm R_1 \cos \theta_1)]^2 + [I_1(X_1 \cos \theta_1 \mp R_1 \sin \theta_1)]^2\}^{1/2} \quad (47)$$

$$g_{fe} = \frac{W_n}{m \cdot V_2^2} \quad (48)$$

The values obtained in equations 41, 42, 46, and 48 are used in the equivalent circuit calculations. Rotor resistance, R_2 , from equation 44 and stator resistance, R_1 , should be corrected to the specified temperature.

6.7.1.2.3 Locked-rotor and load point test (Method 4)

The values of X_1 , X_2 , X_m , and R_{fe} can be determined from the no-load and locked-rotor tests at rated frequency following the procedure in 6.7.1.2.1. The value of R_2 at reduced frequency can be obtained from readings (volts, watts, amperes, slip, stator winding resistance, or stator winding temperature) at a load point using rated voltage or less. The slip shall be measured very carefully. R_2 can be obtained by the following procedure after other motor parameters have been determined from the no-load and locked-rotor tests.

For this method, the machine is run uncoupled (or coupled to some reduced load), the voltage is reduced to give approximately full-load slip, and the slip is measured very carefully. After X_1 has been determined from the locked-rotor impedance tests (see 6.7.1.2), the value of R_2 is obtained as follows:

- a) Calculate V_2 using equation 32.
- b) Calculate θ_2 using equation 33.
- c) Calculate I_{fe} and I_e using equations 34 and 37.
- d) Calculate I_2 using equation 38.
- e) Calculate rotor impedance, Z_2 , using equation 43.
- f) Calculate using equation 44:

$$\frac{R_2}{s} = \sqrt{Z_2^2 - X_2^2}$$

- g) Obtain R_2 by the multiplication of R_2/s by the measured value of slip in per unit of synchronous speed. Correct R_2 to the specified temperature.

6.7.1.3 Stray-load loss (direct method)

6.7.1.3.1 Test Method F

See 5.4.2 or 5.4.3.

6.7.1.3.2 Test Method F1

See 5.4.4.

6.7.2 Calculation form

Form F-F1 (see 10.5) is used to determine the value of total reactance and rotor resistance (except if the alternative test in 6.7.1.2.3 is performed) based on the values of voltage, current, and input power obtained from the no-load and locked-rotor impedance tests. It is arranged on the basis of X_1 and X_2 remaining constant throughout the range of operation of the machine. Should the curve of locked-rotor current vs. voltage depart from a straight line in the range of currents under consideration, each column of calculations in 10.5 should use values of reactance obtained from this curve for the value of I_1 calculated in the column.

The results of the calculations of 10.5 may be plotted in curve form, from which the summary of characteristics in 10.5 can be determined, or iterative calculations can be made to determine the slip corresponding to the desired load points for 10.5.

6.7.3 Calculation of maximum torque

Maximum or breakdown torque in a motor is determined from 10.5 using the following slip value:

$$s = \frac{R_2}{\sqrt{R_1 + (X_1 + X_2)^2}} \quad (49)$$

6.8 Test method C/F, E/F, or E1/F1—Equivalent circuit calibrated with one load point

When a slip current point under load with a stator winding temperature of t_t is available, Method F or Method F1 may be used to determine machine characteristics at other loads. In such cases, R_2 is not determined from the low-frequency impedance test. The following procedure is used:

- 1) Use Form F3 (see 10.7), but start with line 2 with an assumed value of R_2/s for the test load point and the value of R_1 based on stator winding temperature of t_t . After reaching line 21, check calculated value of input current and input power vs. measured values of input current and input power.
- 2) Adjust R_2/s and X_m , and iterate until the calculated value of input power and input current both agree with the measured value of input current and input power within 1%. Other circuit parameters should not be adjusted. (Input power is primarily a function of R_2/s .)
- 3) Obtain R_2 by multiplying the final assumed value of R_2/s by the measured value of slip in per unit of synchronous speed. This procedure establishes the value of R_2 (without temperature correction) to be used in calculating the load performance characteristics.
- 4) Correct R_1 and R_2 to the specified temperature, t_s , in accordance with 5.1.1, and determine performance at desired load points following the format shown in 10.7.

6.8.1 Stray-load loss (indirect method)

6.8.1.1 Test procedure

For Method C/F, the stray-load loss shall be determined as follows:

- 1) For both the motoring and generating load point, determine the average value of stray-load loss, W_{LLave} , following the procedure in 6.5.2, steps 1) through 5).
- 2) For both the motoring and generating load point, determine the average value of rotor current, I_{2ave} , using equation 26.
- 3) The value of stray-load loss, W_{LL} , for any load point is then calculated as

$$W_{LL} = W'_{LL} \left(\frac{I_2}{I_2'} \right)^2 \quad (50)$$

where

W'_{LL} is the average value of stray-load loss, W_{LL} , from step 1)

I_2 is the rotor current determined by solution of the equivalent circuit for the appropriate load point

I_2' is the average value of rotor current, I_{2ave} , from step 2)

The value of stray-load loss, W'_{LL} , reported in 10.7 should correspond to a value of I_2' equal to the average value of rotor current as determined from step 2).

6.8.1.2 Test Method E/F

See 5.4.2 or 5.4.3.

6.8.1.3 Test Method E1/F1

See 5.4.4.

6.8.2 Calculations form

See 10.7.

6.9 Power factor

6.9.1 Indirectly obtained

The power factor is the ratio of watts to volt-amperes. For three-phase machines,

$$\text{power factor} = \frac{\text{watts}}{\sqrt{3} \cdot \text{line to line volts} \cdot \text{lineamps}} \quad (51)$$

6.9.2 Directly obtained

For three-phase machines, the power factor may be checked by equation 52 when the two-wattmeter method is used.

$$\text{power factor} = \frac{1}{\sqrt{1 + 3\left(\frac{W_1 - W_2}{W_1 + W_2}\right)^2}} \quad (52)$$

where

W_1 is the higher reading

W_2 is the lower reading

If W_2 gives a negative reading, it must be considered a negative quantity.

If a polyphase wattmeter is used, the values of the single-phase wattmeter readings can be obtained by opening separately each of the voltage coil circuits of the polyphase wattmeter. With pulsating loads, the power factor obtained by the direct method may be higher than that obtained by the indirect method. The higher value shall be taken as the correct reading. The difference is due to the inclusion in the volt-amperes of the pulsating component of current, which is a function of the load rather than of the machine itself. The power factor determined from the ratio of wattmeter readings is not affected by the presence of pulsating current.

6.9.3 Equivalent circuit calculation (F-F1)

The power factor may be determined from the equivalent circuit by dividing the total resistance by the total impedance. This determination is shown in Form F-F1, line 31 (see 10.7).

7. Other performance tests

7.1 Rotor voltage

On wound-rotor machines, the voltages shall be measured between all rotor terminals, with the rotor locked and its windings open-circuited and with rated voltage being applied to the stator. If any unbalance is detected, it is usual practice to take readings with several rotor positions to determine an average.

7.2 Locked-rotor tests

7.2.1 Current

This test may be performed either to check for quality or to determine performance. When possible, readings shall be taken at rated voltage and frequency since the current is not directly proportional to the voltage because of changes in reactance caused by saturation of the leakage paths. When the test is made to check the quality of squirrel-cage machines, it is possible to omit the mechanical means of locking the rotor by applying single-phase power of rated voltage and frequency to any two of the machine line terminals of a three-phase machine. With a three-phase machine, the line current will be approximately 86% and the power input will be approximately 50% of the corresponding values obtained with polyphase power. The values so

obtained may be compared with those measured on a duplicate unit that has been subjected to a complete test.

7.2.2 Torque

The locked-rotor torque is taken as the minimum torque developed at rest in all angular positions of the rotor. The torque may be measured with a rope and pulley, or with a brake or beam. Wound-rotor motors are always subject to variations in locked-rotor torque, depending on the angular position of the rotor with respect to the stator. For squirrel-cage motors, it is usual practice to lock the rotor in any convenient position. If the locked-rotor torque is not measured directly as mentioned above, the approximate locked-rotor torque may be calculated as follows:

$$T = \frac{k(P_{si} - P_{cu} - P_c)C_1}{n_s} \quad (53)$$

where

P_{si} is the input power to stator, in W

P_{cu} is the stator I^2R loss, in W , at the test current (see 5.1)

P_c is the core loss, in W , at test voltage (see 5.3.5)

n_s is the synchronous speed, in $\frac{r}{min}$

C_1 is a reduction factor (varying between 0.9 and 1.0) to account for nonfundamental losses

k is 9.549 for T , in $N \cdot m$

k is 7.043 for T , in $(lbf \cdot ft)$

7.2.3 Power

Readings of input power shall be taken simultaneously with those of current and torque.

7.3 Tests for speed-torque and speed-current curves

7.3.1 Definitions

7.3.1.1 Speed-torque characteristic

The speed-torque characteristic is the relation between torque and speed, embracing the range from zero to synchronous speed for a motor and from synchronous speed to pull-out speed for an induction generator. This relation, when expressed as a curve, will include maximum (breakdown), pull up or pull out, and locked-rotor torques.

For wound-rotor motors, the torque and current shall be measured between synchronous speed and the speed at which maximum torque occurs. The slip rings shall be short-circuited for this test.

7.3.1.2 Speed-current characteristic

The speed-current characteristic is the relation between current and speed. (This curve is generally plotted on the same sheet as the speed-torque curve, using a common speed scale for both curves.)

7.3.2 Speed-torque curve procedure

Any one of the following methods may be used to obtain data for a speed-torque curve. The selection of the method will depend upon the size and the speed-torque characteristics of the machine and the testing facilities. In all four methods, sufficient test points should be recorded to ensure that reliable curves, including irregularities, can be drawn in the regions of interest from the test data. It is important that the frequency of the power supply be maintained constant throughout the test at the rated value for the motor. For wound-rotor motors, the slip rings shall be short-circuited for this test.

Methods 1 and 4 require the maintenance of constant speed for each reading. Therefore, they cannot be used in regions where the torque of the machine increases with speed more rapidly than that of the loading device. From the results of the following tests, adjusted to rated voltage, curves of torque and current should be plotted vs. speed.

7.3.2.1 Method 1—Measured output

A dc generator that has had its losses previously determined is coupled or belted to the motor being tested. An ac power supply of rated frequency is connected to the motor terminals. The voltage should be as high as can be impressed upon the motor terminals without excessive heating, at least 50% of rated voltage, if possible. The speed of the motor for each test point is controlled by varying the load on the generator.

In this test, readings are taken at speeds between approximately 1/3 synchronous speed and the maximum speed obtainable. The speed should be constant when the readings are taken, so that acceleration or deceleration power does not affect the results. At each speed setting, readings of voltage, current, and speed are taken for the induction motor, and readings of armature voltage and current and field current are taken for the dc generator. Care should be taken not to overheat the motor.

The accuracy of speed measurement is particularly important at low slip. The speed measuring device should be accurately adjusted or calibrated. All points should be read as soon as the meters have settled, without waiting for the slow creep in the indications to disappear.

The total power output of the motor is the sum of the output and losses of the dc generator.

The torque, T , at each speed is calculated using equation 54 as follows:

$$T = \frac{k(P_{GO} + P_{GL})}{n} \quad (54)$$

where

P_{GO} is the output of dc generator, in W

P_{GL} is the losses of dc generator (including friction and windage), in W

n is the test speed of motor, in $\frac{r}{min}$

k is 7.043 for T , in $\text{lb} \cdot \text{ft}$

k is 9.549 for T , in $N \cdot m$

At the speed for the test point, the values of torque and current are ratioed to the specified voltage, V , as described in 7.4.

7.3.2.2 Method 2—Acceleration

In the acceleration method, the motor is started with no load, and the value of acceleration is determined at various speeds. The torque at each speed is determined from the acceleration of the mass of the rotating parts. Accurate measurements of speed and acceleration are an essential requirement of this method. The motor should be operated from a rated frequency ac power source.

The acceleration to be used and, consequently, the duration of the test are determined by the type of instruments that are used to make the measurements. In any case, the accelerating time should be long enough so that electrical transient effects in the instruments and in the motor do not distort the speed-torque curve. The accelerating time must also be long enough to permit recording the necessary number of mechanical and electrical measurements with sufficient accuracy for plotting the required curves (see 7.3.2).

When manually recording the data at each point, the accelerating time may be increased by using a lower applied voltage or by coupling a suitable inertia to the motor shaft.

As the motor accelerates from rest to near synchronous speed, simultaneous readings are taken of line-to-line voltage for one phase, line current in one phase, speed, and time in seconds. A minimum of five sets of readings should be taken during the accelerating period; however, more readings should be taken if possible. If the motor's starting friction is high, or if more accurate data in the zero speed range are desired, the motor can be started rotating in the reverse direction prior to application of power for the acceleration on which measurements are to be taken.

If Method 3 (see 7.3.2.3) is to be used as a check, line power should be taken with a polyphase wattmeter or two single-phase wattmeters at each speed point where data are recorded.

It may sometimes be necessary to take more than one run at different voltages in order to get satisfactory readings throughout the curve, especially when there are appreciable cusps in the speed-torque characteristics.

The torque, T , at each speed is calculated from the acceleration using equation 55 as follows:

$$T = \frac{J}{k} \cdot \frac{dn}{dt} \quad (55)$$

where (in US customary units)

T is the torque, in lbf · ft

J is the moment of inertia of rotating parts, in lb · ft²

$\frac{dn}{dt}$ is the acceleration at each speed, in revolutions per minute per second

k is 307.2

where (in SI units)

T is torque, in N · m

J is the moment of inertia of rotating parts, in (kg · m²)

$\frac{dn}{dt}$ is the acceleration at each speed, in revolutions per minute per second

k is 9.549

At the speed for the test point, the torque and current of the motor are corrected to the specified voltage, V , as described in 7.4.

7.3.2.3 Method 3—Input

In this method, the torque is determined by subtracting the losses in the machine from the input power. It is a valuable check on the other methods, and is particularly useful when the machine cannot be unloaded to determine torque by acceleration. In practice, the method is approximate because the stator losses cannot be readily determined for the actual operating conditions and, therefore, must be approximated. This method is also subject to error in the case of special machines that may have substantial positive or negative harmonic torques that are not readily evaluated.

The machine is started as described in 7.3.2.2, except that it does not have to be unloaded. The input readings called for in 7.3.2.2 are plotted against the speed readings. The line voltage, line current, power, and speed should be plotted vs. time. Average values of the zero speed readings from the locked test, as described in 7.2.2, adjusted to the voltage at which the other readings were taken, should be included.

The torque, T , at each speed is determined from the input power using equation 56.

$$T = \left(\left(\frac{k}{n_s} \right) \cdot \left[P_{si} - P_{cu} - P_c - LL_s - LL_r \left(\frac{n}{n_s} \right)^{0.5} \right] \right) - T_{fw} \quad (56)$$

where

P_{si} is the input power to stator, in W

P_{cu} is the stator I^2R loss, in W , at the test current (see 5.1)

P_c is the core loss, in W , at test voltage (see 5.3.5)

LL_s is the fundamental frequency stray-load loss, in W , at the test current (see 5.4.2.3)

NOTE—If the LL_s component of stray load loss is not available, it may be assumed that the stray load loss is equal to LL_r . If the stray load loss ($LL_s + LL_r$) has been determined from a dynamometer test or a pump-back test, the total value of stray-load loss may be used as the value of LL_r ; or, the value of LL_s may be determined by the method outlined in 5.4.2, and LL_r may be determined as the value of stray load loss minus the value of LL_s .

LL_r is the higher frequencies stray-load loss, in W , at the test current (see 5.4.2.3)

n is test speed, in r/min

n_s is the synchronous speed, in r/min

k is 7.043 for T , in (lbf · ft)

k is 9.549 for T , in N · m

T_{fw} is the motor friction and windage torque at test speed, in (lbf · ft) or N · m

At the speed for the test point, the torque and current of the motor are corrected to the specified voltage, V , as described in 7.4.

7.3.2.4 Method 4—Direct measurement

The torque and current are measured as the machine is loaded at various speeds with a dynamometer or pony brake. At each speed, simultaneous readings of voltage, current, speed, and torque are taken. The test should be taken as near rated voltage as practical, but, if a reduced voltage is used, the motor torque and current should be corrected to the specified voltage as described in 7.4.

7.4 Correction of data for speed-torque, speed-current, and locked-rotor tests run at reduced voltage

When it is necessary to establish values of current and torque at rated voltage, based on tests made at reduced voltage, it should be recognized that, because of saturation of the leakage flux paths, the current may increase by a ratio somewhat greater than the first power of the voltage; and the torque may increase by a ratio somewhat greater than the square of the voltage. The relationship varies with design; however, as a first approximation, the current is calculated as varying directly with voltage, and torque with the square of voltage.

A more exact method of test requires determining the rate of change of current and torque with voltage by establishing speed-torque and speed-current curves for at least two, and preferably for three or more, values of voltage. The reduced-voltage test points should be plotted on log-log paper and corrected to rated voltage using a least square curve fit for maximum accuracy. On speed-torque and speed-current curves, enough points at various speeds must be corrected to provide true representation of the curve over the entire speed range.

8. Temperature test

8.1 Purpose

Temperature tests are made to determine the temperature rise of certain parts of the machine above the ambient temperature when running under a specified loading condition. The following subclauses are guides for the test procedure and treatment of data.

8.2 General instructions

The machine shall be shielded from air currents coming from pulleys, belts, and other machines. A very slight current of air may cause great discrepancies in the temperature test results. Conditions that result in rapid change of ambient air temperature shall not be considered satisfactory for temperature tests. Sufficient floor space shall be provided between machines to allow free circulation of air.

8.2.1 Measuring devices

Temperature measuring devices shall be in accordance with IEEE Std 119-1974. At the start of the temperature test, all instruments shall be checked to make certain that there are no appreciable instrument errors due to stray field effects.

8.2.2 Temperature of rotors and other parts

The temperature of rotors and other parts of totally enclosed machines, for which the thermometer method is used, shall be obtained after shutdown by applying the thermometer to the hottest parts that can be made quickly accessible by removing covers.

8.2.3 Loading method

The loading method for making the temperature test shall be one of the following:

- a) The actual loading method in which the machine is loaded as a motor or generator under the rated (or desired) condition.
- b) Primary-superposed equivalent loading method. A typical condition is shown in figure 4. The machine to be tested is operated at no-load from a main power source, and low-voltage auxiliary power of different frequency is superposed.

Generally, temperature rises are determined by running with the superposed power supplied at a frequency 10 Hz below rated frequency, and with the voltage so adjusted that the primary current is equal to the rated value.

NOTES

1—When the loading for the temperature test is the superposed equivalent loading method per 8.2.3b), the slip loss, per 4.3.2, does not apply, and a tested value of rotor I^2R loss cannot be obtained. Therefore, when equivalent loading is used, calculated rotor I^2R shall be used in determining efficiency by the segregated loss method (see 6.6).

2—Inasmuch as there are oscillatory torques applied to the stator and rotor of the machine supplied with power at two different frequencies, per 8.2.3b), vibration will be abnormal during this condition, and normal criteria for vibration do not apply. Vibration should be monitored and compared against acceptable limits for the machine being tested. After the machine has been heated as described under 8.2.3b), the auxiliary frequency can be removed and vibration can be measured with rated frequency and voltage applied to determine the vibration of the machine operating at normal running temperature. The machine will cool rapidly after removing the auxiliary frequency. Therefore, temperature should be monitored by thermocouple to ensure that vibration is measured while the motor is within 25% of normal operating temperature.

8.3 Methods of measuring temperatures

There are four methods of determining temperatures as follows:

- a) Thermometer
- b) Embedded detector
- c) Winding resistance
- d) Local temperature detector

For general information, refer to IEEE Std 119-1974, and IEEE Std 1-1986 [B1].

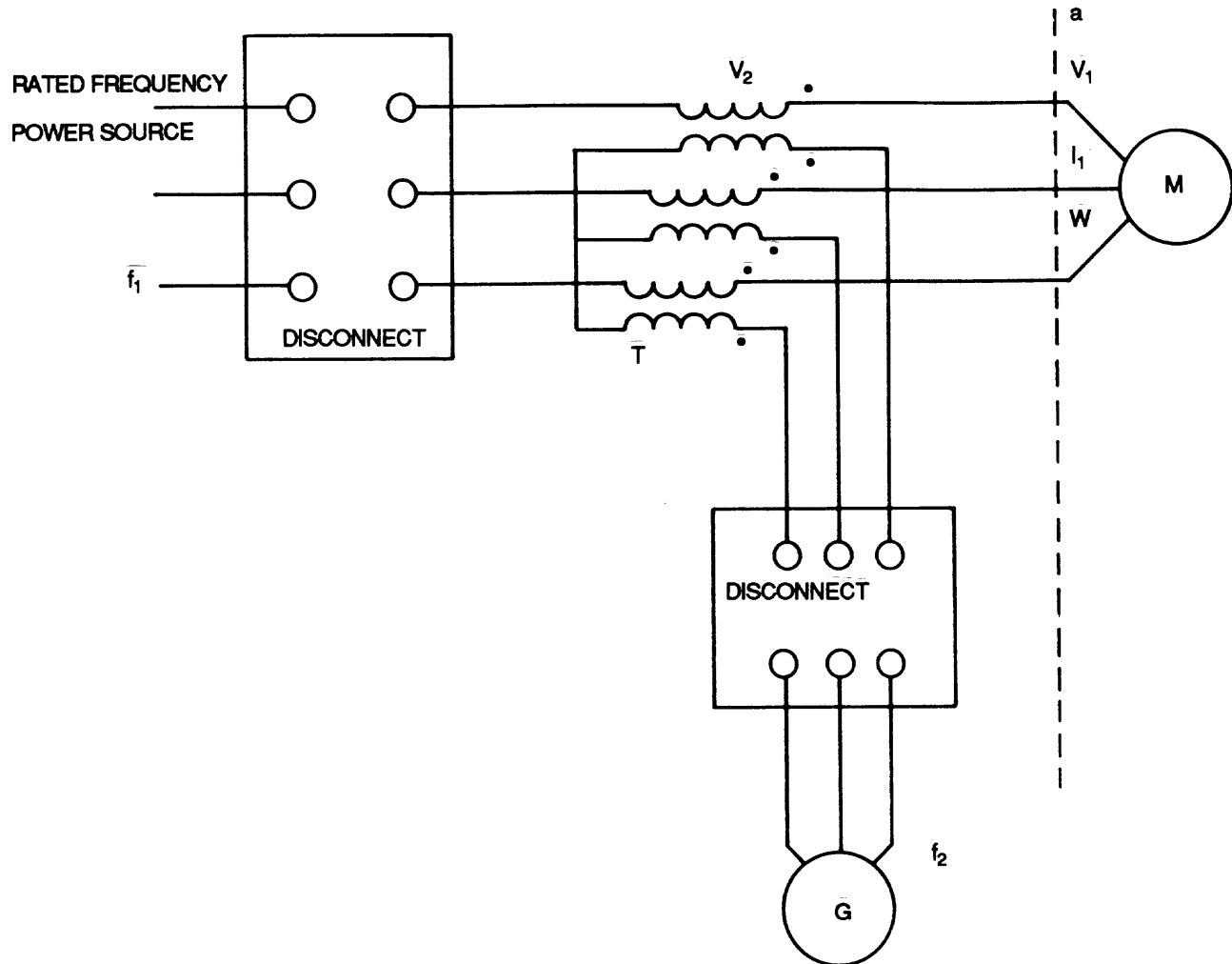

M = motor to be tested
 T = series transformer
 a = connecting points of voltmeter, ammeter, and wattmeter
 G = auxiliary power generator
 V_1 = terminal voltage (rated voltage)
 f_1 = frequency (rated frequency)
 I_1 = primary current of induction machine
 V_2 = auxiliary voltage
 f_2 = auxiliary frequency
 W = input power

NOTES

- 1—The phase rotation of the auxiliary power shall be chosen to have the same direction as that of the main power.
- 2— V_2 will be less than V_1 (usually 10%–20% of V_1). V_2 is the voltage necessary to cause rated current I_1 to flow.

Figure 4—Typical connection for superposed equivalent loading

8.3.1 Method A—Thermometer

This method is the determination of temperature by alcohol thermometers, by resistance thermometers, or by thermocouples, with any of these instruments applied to the hottest part of the machine that is accessible to alcohol thermometers.

8.3.2 Method B—Embedded detector

This method is the determination of temperature by thermocouples or resistance thermometers built into the machine.

Specially designed instruments should be used with resistance thermometers to prevent the introduction of significant error or damage due to heating of the resistance thermometer during measurement. Many ordinary resistance measuring devices may not be suitable because of the relatively large current that may be passed through the resistance element while making the measurement.

8.3.3 Method C—Resistance

This method is the determination of temperature by comparing the resistance of the winding at the temperature to be determined with the resistance at a known temperature. The temperature of the winding is calculated by following the equation:

$$t_t = t_b + \left(\frac{R_t - R_b}{R_b} \right) \cdot (t_b + k) \quad (57)$$

where

- t_t is the total temperature of winding when R_t was measured, in °C
- R_t is the resistance measured during test, in Ω
- R_b is the reference value of resistance previously measured at known temperature t_b , in Ω
- t_b is the temperature of winding when reference value of resistance R_b was measured, in °C
- k is 234.5 for 100% International Annealed Copper Standard (IACS) conductivity copper
- k is 225 for aluminum, based on a volume conductivity of 62%

NOTE—For other winding materials, a suitable value of k (inferred temperature for zero resistance) must be used.

Since a small error in measuring resistance will make a comparatively large error in determining temperature, the winding resistance should be measured by a double bridge, or other means of equivalent accuracy, and checked by a second instrument, if possible. When using equation 57 to calculate the temperature, both the reference resistance and the test resistance should be measured using the same test equipment.

In a squirrel-cage machine, the change in rotor resistance due to heating results in a change in slip. For a given value of torque, the temperature of the rotor can be indirectly determined from the hot slip reading, S_h , and cold slip reading, S_c , by substituting S_h for R_t and S_c for R_b in equation 57. The slip shall be accurately determined for both hot and cold conditions. Small errors in the slip values may occasion considerable errors in the calculated temperature from which the temperature rise is obtained.

8.3.4 Method D—Local temperature detector

The local temperature of various parts of a machine can be determined using a local temperature detector. The maximum dimension of the detecting element should not exceed 2 in (5.08 cm). The detecting element is placed in thermal proximity to the part at which the local temperature is to be measured. Examples of local temperature detectors are

- a) Thermocouples
- b) Small resistance thermometers
- c) Thermistors

These are frequently installed as permanent parts of a machine in places not accessible to alcohol thermometers. They are used to determine the local temperature of winding conductors, core laminations within a package, and winding temperature between coil sides. Since the temperatures measured by local temperature detectors may deviate substantially from those determined by the thermometer method, the embedded-detector method, and the resistance method, the temperatures so measured should not be interpreted in relation to standards written in terms of these other methods.

8.4 Temperature readings

8.4.1 General

The following subclauses describe three methods of temperature measurement. These are used to measure the temperature of the windings, the stator core, the incoming cold coolant, and the exhaust hot coolant. Each method of measurement is best suited for particular parts of a machine. Thus, in a given test, it may be desirable to use all three methods to measure the temperature in the various parts of the machine.

8.4.2 Thermometer method

Temperatures taken by the thermometer method (see 8.3.1) may be measured on the following parts during the temperature tests and, if specified, after shutdown:

- a) Stator coils, in at least two places
- b) Stator core, in at least two places
- c) Ambient
- d) Air discharged from frame or air discharge ducts, or internal coolant discharged to the inlet of coolers of machines with recirculating cooling system
- e) Frame
- f) Bearings (when part of the machine)

The temperature sensing elements should be located to obtain the highest temperatures, except for ingoing and discharge air or other coolant temperature, for which they should be placed to obtain average values.

8.4.3 Embedded-detector method

Temperatures of the windings of machines equipped with embedded detectors should be determined by the embedded-detector method (see 8.3.2) during the temperature test. Temperature measurements of all embedded detectors should be recorded, and the maximum of these values should be reported as the temperature of the winding by embedded detector. Readings after shutdown are not normally required.

8.4.4 Resistance method for windings

Temperatures of the stator (and rotor of wound-rotor machines) winding may be determined by the resistance method (see 8.3.3) after shutdown. The resistance should be measured across any two line terminals for which a reference value of resistance has been measured at a known temperature. The resistance should be measured directly at the machine terminals.

8.5 Measurement of ambient temperature

For the procedure to be followed in the measurement of ambient temperature, see IEEE Std 119-1974.

8.6 Procedure

The machine may be loaded by one of the methods outlined in 8.2.3. The loading may be determined by direct measurement of output or input.

A machine having multiple ratings (such as a multispeed or oil-well service machine) shall be tested at the rating that produces the greatest temperature rise. Where this cannot be predetermined, the machine shall be separately tested at each rating.

A dual-frequency machine may be tested at whichever frequency is available, provided that the load is adjusted to be equivalent to the frequency that results in the maximum temperature rise.

A machine having a service factor greater than 1.0 shall be tested at the service factor load to establish that the machine meets insulation class temperature limits, except when temperature rise at a specified loading forms part of the machine rating. However, the temperature rise at 1.0 service factor shall be used in calculating machine performance in accordance with 5.1.1.

When the temperature run is at the service factor load rather than rated load (1.0 sf), the temperature rise by resistance of the motor at rated load can be derived by varying the temperature rise by the square of the current. For the efficiency calculations, the total temperature will be the rise at rated load plus 25 °C.

$$TR_{\text{rated}} = TR_{\text{test}} \cdot \left[\frac{I_{\text{rated}}}{I_{\text{test}}} \right]^2 \quad (58)$$

8.6.1 Initial conditions

The test shall be continued for the specified time (for machines not continuously rated), or until constant temperatures have been reached. Unless otherwise specified, a short-time test shall commence only when machine parts are within 5 °C of the ambient temperature.

8.6.2 Permissible overloading

On continuously-rated machines, when a long time is required to attain steady temperature, reasonable (25% to 50%) overloads during the preliminary heating period are permissible in order to shorten the time of test.

8.6.3 Termination of test

For continuously rated machines, readings shall be taken at intervals of 1/2 h or less. For noncontinuously rated machines, readings shall be taken at intervals consistent with the time rating. For continuous rated

machines, the temperature test shall continue until there is 1 °C or less change in temperature rise between two successive readings.

8.6.4 Resistance at shutdown

The measurement of temperatures after shutdown by the resistance method requires a quick shutdown of the machine at the end of the temperature test. A carefully planned procedure and an adequate number of people are required to obtain readings soon enough to give reliable data.

If the initial resistance reading is obtained within the time interval indicated in Table 3, this reading is accepted as the temperature measurement.

Table 3—Maximum time delay in temperature measurements

Rating	Time delay after switching off power (seconds)
50 kVA or hp, and less	30
Above 50 kVA or hp, to 200 kVA or hp	90
Above 200 kVA or hp	120

If the initial resistance reading cannot be made within the time delay given by the table, it shall be made as soon as possible, and additional resistance readings shall be taken at intervals of 30–60 s for a minimum of 10 readings.

A curve of these readings shall be plotted as a function of time, and shall be extrapolated to the time delay given by Table 3 for the rating of the machine. A semilogarithmic plot is recommended, in which resistance is plotted on the logarithmic scale. The value of resistance thus obtained shall be considered as the resistance at shutdown. If successive measurements show increasing temperatures after shutdown, the highest value shall be taken. Where the first reading cannot be taken within twice the time delay given by Table 3, the time shall be subject to agreement.

8.6.5 Care in measurement

Extreme care shall be taken to secure accurate resistance measurements, since a small error in measuring resistance will cause a comparatively large error in determining the temperature. Resistance measurements shall be made as outlined in IEEE Std 118-1978.

8.7 Temperature rise

When the machine is ventilated by the immediately surrounding air, the temperature rise is the observed machine temperature minus the ambient temperature. When the machine is ventilated by air obtained from a remote source or a heat exchanger, the temperature rise is the observed machine temperature minus the ingoing air temperature entering the machine.

Machines may be tested at any altitude not exceeding 3300 ft (1000 m) and with cooling air temperatures between 10° C and 40 °C without correction of temperature rise.

NOTE—At higher altitudes, the temperature rise will be greater than at sea level. While an exact conversion is not available, a commonly used method allows for the influence of altitude. For each 330 ft (100 m) above 3300 ft (1000 m), the temperature rise is reduced by 1% to obtain the rise expected at sea level.

9. Miscellaneous tests

9.1 Insulation resistance

For maintenance purposes, insulation resistance tests are of value. All accessories, such as surge capacitors, surge arresters, current transformers, etc., that have leads located at the machine terminals shall be disconnected during this test, with the leads connected together and to the frame or core.

For test methods, see IEEE Std 43-1974.

9.2 High-potential test

9.2.1 Measurement

For measurement of high-potential test voltage, see IEEE Std 4-1995. The voltmeter method of measurement is commonly used.

9.2.2 Connections

The high-potential test voltage shall be successively applied between each electric circuit and the frame, with the windings not under test and the other metal parts connected to the frame. Interconnected polyphase windings are considered as one circuit. All accessories, such as surge arresters, current transformers, etc., that have leads located at the machine terminals shall be disconnected during this test, with the leads connected together and to the frame or core.

9.2.2.1 Voltage application

No leads shall be left unconnected during the test as this may cause an extremely severe stress at some point of the winding. In performing the test, the voltage shall be increased to full value as rapidly as possible while still maintaining an accurate meter reading; and the full voltage should be maintained for 1 min. It should then be reduced at a rate that will bring it to 1/4 value or less in not more than 15 s.

CAUTION

Due to the high voltage used, high-potential tests should be conducted only by experienced personnel, and adequate safety precautions should be taken to avoid injury to personnel and damage to property. For the procedures recommended, refer to IEEE Std 4-1995 and IEEE Std 62-1978 [B2].

9.3 Winding resistance measurements

For the procedures recommended in the measurement of resistance, refer to IEEE Std 118-1978, IEEE Std 119-1974, or 8.3.3 of this standard.

9.4 Shaft currents and bearing insulation

Shaft currents can flow in rotating machinery as a consequence of electromagnetically developed voltages in the shaft or frame.

In electrical machines, any unbalance in the magnetic circuits, or in the electrical phase currents that encircle a shaft, can create flux linkages with the rotating system. When the shaft rotates, these linkages can produce an electric potential difference between shaft ends. This voltage is capable of driving a circulating current in a shaft-to-frame loop by using two bearings to complete the circuit.

If the opposite drive end bearing (or both bearings) is/are isolated from the frame, the conducting path is impeded by the insulation, and the circulating shaft current in that machine is inhibited. If only the drive end bearing is insulated, however, the current may be able to circulate by using the opposite end bearing in conjunction with an uninsulated bearing in the interconnected equipment to complete the circuit.

9.4.1 Test to measure shaft potential for circulating shaft currents

In machines that have insulation on all bearings (or all but one bearing), a test can be conducted to detect the presence of shaft potential while the unit is operating under rated speed and voltage.

This test can also be applied to machines that have insulating properties in all bearing oil films.

First, a shaft brush is used to short out the uninsulated bearing (or one bearing, if all are insulated). This fixed brush is applied to the shaft near the bearing and connected to the frame with a short piece of low resistance conductor.

The test is completed by measuring the shaft potential to the frame at each of the other bearings. A high-impedance oscilloscope should be utilized and connected with one lead grounded to the frame and the other lead attached to a shaft brush. This brush is then applied to a shaft section near each bearing and the peak voltages are measured.

It is preferable to use a low-impedance shielded conductor for the oscilloscope leads to minimize electromagnetic interference. This shield should be grounded at one end only.

If an oscilloscope is not available for the test, a high-impedance voltmeter can be used. Both ac and dc voltages should be measured at each bearing. The peak voltage can be roughly approximated by adding the dc level and 1.4 times the ac rms level. This estimated peak voltage, however, may be considerably below the actual peak value.

An alternate method involves measuring the ac voltage with brushes contacting opposite ends of the shaft while the machine is operating at rated voltage and speed.

9.4.2 Test to measure possible level of shaft current

This test can be conducted on machines described in 9.4.1. The procedure is identical to that of 9.4.1, with the exception that a low-resistance ammeter is used in place of the oscilloscope.

9.4.3 Test to measure bearing insulation resistance

9.4.3.1 Method 1

The most reliable check on bearing insulation is performed with the unit at rest. If only one bearing is insulated, a layer of insulating paper should be applied under the uninsulated bearing journal to insulate the shaft from the bearing. Couplings to adjacent units should be disengaged if they are not insulated.

A low-voltage ohmmeter should be used to make a preliminary check at each insulated bearing. With one meter lead applied to the shaft and the other to the frame (across the insulation), the bearing insulation resistance can be measured.

On some machines, bearings are provided with two layers of insulation, with a metallic separator between them. On these units, the above described tests should be conducted between the metallic separator and the machine frame. The test can be conducted while the machine is running, but it is preferable to conduct the test with the machine at rest. The test should be supplemented with a careful visual inspection to ensure that there are no possible parallel paths that are uninsulated.

9.4.3.2 Method 2

A layer of heavy paper is placed around the shaft to insulate the journals of the uninsulated bearings. The coupling of the driving or driven units should be disengaged, if it is not insulated. Then, from a 110–125 V source with either a filament lamp suitable for the circuit voltage or a voltmeter of approximately 150 V full scale with a resistance in the range of 100–300 Ω/V placed in series with the voltage source, two leads should be run, one to the insulated bearing and the other to the frame (across the insulation). If the lamp filament does not show color (or if the reading of the voltmeter does not exceed 60 V), the insulation may be considered satisfactory.

A 500 V megohmmeter may also be used. This is much more sensitive than the above method and may tend to reject insulation, which, in reality, is adequate to prevent the small shaft voltage from causing injurious current. See 9.4.3.1.

9.5 Noise

See IEEE Std 85-1973.

9.6 Balance and vibration

9.6.1 Motor and generator rotors

Motor and generator rotors should be dynamically balanced with a half key in place.

9.6.2 Mounting conditions

Mounting conditions will affect the vibration of a machine. To obtain measurements that are as nearly independent of mounting conditions as possible, the machine shall be placed on flexible pads or springs. The compression of the flexible pads or springs (downward) by the weight of the machine alone shall not be less than the values shown in table 4.

The pads or springs shall be selected so that the compression is not more than half the original thickness.

When the machine, either because of its size or for some other reason, cannot be mounted on flexible pads or springs, the machine shall be mounted on a foundation in which the natural frequencies of the motor-foundation system are at least 25% away from the rotational exciting frequency.

Table 4—Vibration mounts

Speed r/min	Minimum compression	
	in	mm
900	1	25.4
1800	1/4	6.35
3600	1/16	1.6
7200	1/64	0.4

9.6.3 Instrumentation measuring devices

Displacement, velocity, or acceleration measuring devices (transducers) may be used to measure and record vibration. Displacement measuring transducers are, in general, more sensitive at low frequencies encountered in motors with rigid bearings or at speeds of 1000 r/min and below. Velocity transducers are more sensitive at medium frequencies and accelerometers are more sensitive for speeds above 10 000 r/min.

9.6.4 Procedure

With the machine running at no-load, record vibration measurements in the following locations and by the method indicated:

- 1) Bearing housings—displacement, velocity transducer or accelerometer (readings in vertical, horizontal, and axial directions).
- 2) Center of frame—displacement, velocity transducer or accelerometer (readings in horizontal plane).
- 3) Shaft vibration (when specified)—shaft velocity transducer or accelerometer with shaft rider, or noncontacting proximity probes (readings in the vertical and horizontal direction or at two locations 90° apart). When the probes are not positioned along the horizontal and vertical axes, consideration shall be given to resolving the measurements to those axes. On machines with proximity probes or provisions for proximity probes, the combined electrical and mechanical run-out value shall be recorded.

The double amplitude displacement is taken as the measure of the vibration.

9.7 Overspeed

If overspeed tests are specified, every precaution shall be taken to protect personnel and equipment.

10. Forms

10.1 Form A — Method A

Type _____ Design _____ Frame _____ hp/kW _____ Phase _____
 Frequency _____ Volts _____ Synchronous r/min _____ Serial No. _____
 Degrees C Temperature Rise _____ Time Rating _____ Model No. _____

Test Point (Motoring)(Generating)	1	2	3	4	5	6
(<i>t</i> ₁) Stator Winding Temperature, in °C						
Ambient Temperature, in °C						
Frequency, in Hz						
Observed Slip, in r/min						
Corrected Slip, in r/min*						
Speed, in r/min						
Torque _____ †						
(1) Dynamometer Correction _____ †						
(2) Corrected Torque _____ †						
(3) Shaft Power, in hp						
Line Current, in A						
Power Factor, in %						
Stator Power, in W						
(a) Stator I ² R Loss, in W, at (<i>t</i> ₁) °C						
(b) Stator I ² R Loss, in W, at (<i>t</i> ₂)						
(4) Stator Power Correction = (a) – (b)						
(5) Corrected Stator Power, in W						
(6) Efficiency, in %						

Performance Curve _____

*See 4.3.2.2.

†Indicate torque units as N·m or lb·ft.

Summary of Characteristics

Load, in % of rated	25	50	75	100	125	150
Power Factor, in %						
Efficiency, in %						
Speed, in r/min						
Line Current, in A						

*t*₁ = temperature of stator winding as determined from stator resistance or by temperature detector during test

*t*₂ = specified temperature for resistance correction (see 5.1.1)

(1) "Corrects" for windage and bearing loss torque of dynamometer and is equal to

$$k \frac{(A - B)}{n} - C$$

where

A = power, in W, required to drive machine as a motor when coupled to dynamometer with dynamometer armature circuit open. *A* = (watts in – stator I²R)(1 – slip).

B = power, in W, required to drive machine as a motor when running free and uncoupled. *B* = watts in – stator I²R.

C = torque output registered by dynamometer during test "A."

k = 9.549 for torque, in N·m.

k = 7.043 for torque, in lb·ft.

n = rotational speed, in r/min.

(2) Corrected torque is equal to observed torque plus correction (1) for motoring, and minus correction (1) for generating.

(5) This value is equal to observed power, in W, plus correction (4) for motoring, and minus correction (4) for generating.

(6) Percent efficiency = [(3)/(5)] · 74570 for motoring, and [(5)/(3)] · (100/745.7) for generating.

Figure 6—Form A
Method A: Input-output test of induction machine

10.2 Form B—Method B

Type _____ Design _____ Frame _____ hp/kW _____ Phase _____
 Frequency _____ Volts _____ Synchronous r/min _____ Serial No. _____
 Degrees C Temperature Rise/Time Rating _____ Model No. _____

Average Cold Stator Winding Resistance Between Terminals (1) _____ Ohms @ (2) _____ °C							
Rated Load Heat Run Stator Winding Resistance Between Terminals (3) _____ Ohms @ (4) _____ °C in (5) _____ °C Ambient							
Item	Description (Motoring)(Generating)	1	2	3	4	5	6
6	Ambient Temperature, in °C						
7	(<i>t</i> _s) Stator Winding Temperature, in °C						
8	Frequency, in Hz						
9	Synchronous Speed, in r/min						
10	Slip Speed, in r/min						
11	Speed, in r/min						
12	Line-to-Line Voltage, in V						
13	Line Current, in A						
14	Stator Power, in W						
15	Core Loss, in W						
16	Stator <i>I</i> ² <i>R</i> Loss, in W, at (<i>t</i> _s) °C						
17	Power Across Air Gap, in W						
18	Rotor <i>I</i> ² <i>R</i> Loss, in W						
19	Friction and Windage Loss, in W						
20	Total Conventional Loss, in W						
21	Torque _____ *						
22	Dynamometer Correction _____ *						
23	Corrected Torque _____ *						
24	Shaft Power, in W						
25	Apparent Total Loss, in W						
26	Stray-Load Loss, in W						
Intercept _____ Slope _____ Correlation Factor _____ Point Deleted _____							
27	Stator <i>I</i> ² <i>R</i> Loss, in W, at (<i>t</i> _s) °C						
28	Corrected Power Across Air Gap, in W						
29	Corrected Slip, in r/min						
30	Corrected Speed, in r/min						
31	Rotor <i>I</i> ² <i>R</i> Loss, in W, at (<i>t</i> _s) °C						
32	Corrected Stray-Load Loss, in W						
33	Corrected Total Loss, in W						
34	Corrected Shaft Power, in W						
35	Shaft Power, in hp						
36	Efficiency, in %						
37	Power Factor, in %						

*t*_s = temperature of stator winding as determined from stator resistance or temperature detector during test.
 *Indicate torque units as N · m or lb · ft

Summary of Characteristics

Load, in % of rated	25	50	75	100	125	150
Power Factor, in %						
Efficiency, in %						
Speed, in r/min						
Line Current, in A						

Figure 7—Form B
Method B: Calculation form for input-output test of induction machine with segregation of losses and smoothing of stray-load loss

- (9) Is equal to $120 \cdot (8) / \text{number of poles}$
 (10) Is equal to (9) - (11) when speed is measured
 (11) Is equal to (9) - (10) when slip is measured. For generator operation slip is negative.
 (16) Is equal to $1.5 \cdot (13)^2 \cdot (1) \cdot [k_1 + (7)] / [k_1 + (2)]$ where $k_1 = 234.5$ for 100% IACS conductivity copper or 225 for aluminum, based on a volume conductivity of 62%
 (17) Is equal to (14)-(15)-(16) for motor operation, and (14)+(15)+(16) for generator operation.
 (18) Is equal to $[(17) \cdot (10)] / (9)$ positive for motor or generator operation
 (20) Is equal to (15)+(16)+(18)+(19)
 (22) "Corrects" for windage and bearing loss torque of dynamometer, and is equal to

$$\frac{k(W_A - W_B)}{n} - C$$

where

$$W_A = (P_1 - W_1 - W_h) \cdot (1 - s_1)$$

$$W_B = P_o - W_o - W_h$$

P_1 = input power, in W, required to drive machine as a motor when coupled to dynamometer with dynamometer armature circuit open (Test "A")

W_1 = stator I^2R loss, in W, during Test "A"

s_1 = slip, in pu, during Test "A"

P_o = input power, in W, required to drive machine as a motor running free and uncoupled (Test "B")

W_o = stator I^2R loss, in W, during Test "B"

W_h = core loss, in W

C = torque output registered by dynamometer during Test "A"

k = 9.549 for torque, in N·m

k = 7.043 for torque, in lbf·ft

n = rotational speed, in r/min during Test "A"

- (23) Is equal to (21)+(22) for motor operation and (21)-(22) for generator operation
 (24) Is equal to $[(23) \cdot (11)] / k_2$
 (25) Is equal to (14) - (24) for motor operation, and (24) - (14) for generator operation.
 (26) Is equal to (25) - (20).
 (27) Is equal to $1.5 \cdot (13)^2 \cdot (3) \cdot [k_1 + (4) \cdot (5) + 25^\circ\text{C}] / [k_1 + (4)]$.
 (28) Is equal to $[(29) \cdot (9)] \cdot [(14) - (27) - (15)]$
 (29) See 4.3.2.2, Eq 4.
 (30) Is equal to synchronous speed - (29).

(31) Is equal to $\frac{(28) \cdot (29)}{(9)}$ (positive for motor or generator operation)

(32) Is equal to AT^2
 where

A = slope of the curve of (26) vs. (23)² using a linear regression analysis, see 6.4.2.7

T = corrected torque = (23)

- (33) Is equal to (15) + (19) + (27) + (31) + (32).
 (34) Is equal to (14) - (33) for motor operation, and (14) + (33) for generator operation.
 (35) Is equal to (34) / 745.7
 (36) Is equal to $100 \cdot (34) / (14)$ for motor operation, and $100 \cdot (14) / (34)$ for generator operation.

(37) Is equal to $\frac{(14) \cdot 100}{m \cdot (12) \cdot (13)}$

where $m = \sqrt{3}$ for three phase power

Motoring:

Summary of characteristics obtained by plotting line current (13), speed (30), and efficiency (36) vs. output hp (35), then curve fitting the data to set these values at precise hp load points. Power factor is computed for each precise load point from its amperes, volts, and input watts, where input watts is computed as

$$\text{input watts} = \frac{\text{hp} \cdot 745.7 \cdot 100}{\text{efficiency in \%}}$$

Generating:

Summary of characteristics obtained by plotting line current (13), speed (30), and efficiency (36) vs. output watts (14), then curve fitting the data to set these values at precise kW load points. Power factor is computed for each precise load point from its amperes, volts, and output watts.

**Figure 7 (con't.) Form B—
Method B: Calculation form for input-output test of induction machine with
segregation of losses and smoothing of stray-load loss**

10.3 Form C—Method C

Type _____ Design _____ Frame _____ hp/kW _____ Phase _____
 Frequency _____ Volts _____ Synchronous r/min _____ Serial No. _____
 Degrees C Temperature Rise Time Rating _____ Model No. _____

Stator Winding Resistance Between Terminals _____ Ohms @ _____ °C							
Specified Temperature for Resistance Correction (t_s) = _____ (See 5.1.1)							
Item	Description (Motoring)(Generating)	1	2	3	4	5	6
1	Ambient Temperature, in °C						
2	(t_s)* Stator Winding Temperature, in °C						
3	Frequency, Hz						
4	Slip, in r/min						
5	Speed, in r/min						
6	Line-to-Line Voltage, in V						
7	Line Current, in A						
8	Stator Power, in W						
9	Core Loss, in W						
10	Stator I^2R Loss, in W, at (t_s) °C						
11	Power Across the Gap, in W						
12	Rotor I^2R Loss, in W						
13	Friction and Windage Loss, in W						
14	Total Conventional Loss, in W						
15	Rotor Current, in A						
16	Average Rotor Current, in A						
17	Average Stray-Load Loss, in W						
Intercept _____ Slope _____ Correlation Factor _____ Point Deleted _____							
18	Stator I^2R Loss, in W, at (t_s) °C						
19	Corrected Power Across the Gap, in W						
20	Corrected Slip, in r/min						
21	Corrected Speed, in r/min						
22	Rotor I^2R Loss, in W, at (t_s) °C						
23	Corrected Stray-Load Loss, in W						
24	Corrected Total Loss, in W						
25	Corrected Shaft Power, in W						
26	Shaft Power, in hp						
27	Efficiency, in %						
28	Power Factor, in %						

* t_s = temperature of stator winding as determined from stator resistance or temperature detector during test.

Summary of Characteristics

Load, in % of rated	25	50	75	100	125	150
Power Factor, in %						
Efficiency, in %						
Speed, in r/min						
Line Current, in A						

Figure 8—Form C
 Method C: Duplicate machine test of induction machine with segregation of losses and smoothing of stray-load loss

- (4) For generator operation, slip is negative.
 (5) Is equal to synchronous speed – (4) where synchronous speed = $120 \cdot \frac{(3)}{\text{poles}}$
 (11) Is equal to (8) – (9) – (10) for motor operation, and (8) + (9) + (10) for generator operation
 (12) Is Equal to $\frac{(11) \cdot (4)}{\text{Syn. r/min}}$ (positive for motor or generator operation)
 (14) Is equal to (9) + (10) + (12) + (13)
 (15) $I_2 = \sqrt{I^2 - I_o^2}$

where

- I_2 = value of the rotor current for which the stray-load loss is to be determined
 I_o = value of no-load current
 I = value of the stator line current for which the stray-load loss is to be determined

- (16) Is equal to the average value of (15) motoring and generating.
 (17) See 6.5.2.
 (19) Is equal to (8) – (9) – (18) for motor operation, and (8) + (9) + (18) for generator operation.
 (20) See 4.3.2.2.
 (21) Is equal to synchronous speed – (20).
 (22) Is equal to $\frac{(19) \cdot (20)}{\text{Syn. r/min}}$ (positive for motor or generator operation).
 (23) Is equal to $A \cdot (I_2)^2$

where

- A = slope of the curve of (17) vs. (16)² using a linear regression analysis see 6.5.2.1
 I_2 = rotor current (motoring or generating, as appropriate)

- (24) Is equal to (9) + (13) + (18) + (22) + (23).
 (25) Is equal to (8) – (24) for motor operation, and (8) + (24) for generator operation.
 (26) Is equal to $\frac{(25)}{745.7}$
 (27) Is equal to (25) · $\frac{100}{(8)}$ for motor operation, and (8) · $\frac{100}{(25)}$ for generator operation.
 (28) Is equal to $\frac{(8) \cdot 100}{m \cdot (6) \cdot (7)}$

where

$$m = \sqrt{3} \text{ for three-phase power}$$

Motoring:

Summary of characteristics obtained by plotting line current (7), speed (21), and efficiency (27) vs. output hp (26) or watts, then curve fitting the data to set these values at precise hp load points. Power factor is computed for each precise load point from its amperes, volts, and input watts, where input watts is computed as

$$\text{input watts} = \frac{\text{hp} \cdot 745.7 \cdot 100}{\text{efficiency in \%}}$$

Generating:

Summary of characteristics obtained by plotting line current (7), speed (21), and efficiency (27) vs. output watts (8), then curve fitting the data to set these values at precise output watt load points. Power factor is computed for each precise load point from its amperes, volts, and output watts.

Figure 8 (con't.)—Form C
Method C: Duplicate machine test of induction machine with segregation of losses and smoothing of stray-load loss

10.4 Form E-E1—Method E-E1

Type _____ Design _____ Frame _____ hp/kW _____ Phase _____
 Frequency _____ Volts _____ Synchronous r/min _____ Serial No. _____
 Degrees C Temperature Rise _____ Time Rating _____ Model No. _____

Stator Winding Resistance Between Terminals _____ Ohms @ _____ °C							
Specified Temperature for Resistance Correction (t_s) = _____ (See 5.1.1)							
(Test)(Standard) *	Description (Motoring)(Generating)	_____ (watts) @ I_2 (amperes)					
Item		1	2	3	4	5	6
1	Ambient Temperature, in °C						
2	(t_s) [†] Stator Winding Temperature, in °C						
3	Frequency, in Hz						
4	Observed Slip, in r/min						
5	Corrected Slip, in r/min						
6	Corrected Speed, in r/min						
7	Line-to-Line Voltage, in V						
8	Line Current, in A						
9	Stator Power, in W						
10	Core Loss, in W						
11	Stator I^2R Loss, in W, at (t_s) °C						
12	Power Across the Gap, in W						
13	Rotor I^2R Loss, in W						
14	Friction and Windage Loss, in W						
15	Rotor Current, in A						
16	Stray-Load Loss, in W						
17	Total Loss, in W						
18	Shaft Power, in W						
19	Shaft Power, in hp						
20	Efficiency, in %						
21	Power Factor, in %						

*Method E — see 5.4.2, Method E1 — See 5.4.4

[†] t_s = temperature of stator winding as determined from stator resistance or temperature detectors during test.

Summary of Characteristics

Load, in % of rated	25	50	75	100	125	150
Power Factor, in %						
Efficiency, in %						
Speed, in r/min						
Line Current, in A						

Figure 9—Form E-E1
 Method E-E1: Segregated losses performance of induction machine
 based on electric power measurement

- (4) For generator operation, slip is negative.
 (5) See 4.3.2.2.
 (6) Equals Synchronous Speed – (5)
 (12) Is equal to (9) – (10) – (11) for motor operation, and (9) + (10) + (11) for generator operation
 (13) Is Equal to (12) · $\frac{(5)}{\text{Syn. r/min}}$ (positive for motor or generator operation)
 (15) $I_2 = \sqrt{I^2 - I_o^2}$

where

- I_2 = value of the rotor current for which the stray-load loss is to be determined
 I_o = value of no-load current
 I = value of the stator line current for which the stray-load loss is to be determined

- (16) Is equal to $W_{LL}' \cdot \left[\frac{(15)}{I_2} \right]^2$
 (17) Is equal to (10) + (11) + (13) + (14) + (16)
 (18) Is equal to (9) – (17) for motor operation, and (9) + (17) for generator operation.
 (19) Is equal to $\frac{(18)}{745.7}$
 (20) Is equal to $\left[\frac{(18)}{(9)} \right] \cdot 100$ for motor operation, and $\left[\frac{(9)}{(18)} \right]$ for generating operation.
 (21) Is equal to $\frac{(9) \cdot 100}{m \cdot (7) \cdot (8)}$

where

$$m = \sqrt{3} \text{ for three-phase power}$$

Motoring:

Summary of characteristics obtained by plotting line current (8), speed (6), and efficiency (20) vs. output hp (19) or watts, then curve fitting the data to set these values at precise load points. Power factor is computed for each load point from its amperes, volts, and input watts, where input watts is computed as

$$\text{input watts} = \frac{\text{hp} \cdot 745.7 \cdot 100}{\text{efficiency in \%}}$$

Generating:

Summary of characteristics obtained by plotting line current (8), speed (6), and efficiency (20) vs. output watts (9), then curve fitting the data to set these values at precise output watt load points. Power factor is computed for each precise load point from its amperes, volts, and output watts.

Figure 9 (con't.)—Form E-E1
Method E-E1: Segregated losses performance of induction machine
based on electric power measurement

10.5 Form F1—Method F-F1

Procedure

When impedance data are determined following Methods 1 or 2 (see 6.7.1.2) a relationship between x_1 and x_2 must be assumed. When design details are available, use the calculated ratio x_1/x_2 .

Otherwise, use

$$\left(\frac{x_1}{x_2}\right) = 1.0 \text{ for Design A, Design D, and wound-rotor motors.}$$

$$\left(\frac{x_1}{x_2}\right) = 0.67 \text{ for Design B motors}$$

$$\left(\frac{x_1}{x_2}\right) = 0.43 \text{ for Design C motors}$$

$$VAR = \sqrt{(mVI_1)^2 - W^2}$$

$$x_M = \frac{mV_o^2}{VAR_o - mI_{1o}^2 x_1} \left(\frac{1}{1 + \frac{x_1}{x_M}} \right)^2 \quad (\text{Eq 1})$$

$$x_{1L} = \frac{VAR_L}{mI_{1L}^2 \left(1 + \frac{x_1}{x_2} + \frac{x_1}{x_M} \right)} \left(\frac{x_1}{x_2} + \frac{x_1}{x_M} \right) \quad (\text{Eq 2})$$

$$x_1 = \frac{f}{f_L} x_{1L} \quad (\text{Eq 3})$$

Equations 1, 2, and 3 may be solved as follows:

- (1) Solve Eq 1 for x_M , assuming a value of x_1/x_M and x_1 .
- (2) Solve Eq 2 for x_{1L} , using the value of x_1/x_M from (1).
- (3) Solve Eq 3 for x_1 .
- (4) Solve Eq 1 for x_M , using x_1 from (3) and a ratio of x_1/x_M from (1) and (3).
- (5) Continue iteration solution until stable values of x_1 and x_M are obtained within 0.1%.

$$b_M = \frac{1}{x_M} \quad (\text{Eq 4})$$

$$x_2 = \frac{x_1}{\left(\frac{x_1}{x_2}\right)} \quad (\text{Eq 5})$$

$$W_h = W_o - W_f - mI_{1o}^2 r_1' \quad (\text{Eq 6})$$

Determine W_f per 5.3.4

NOTE: Unless otherwise noted, all impedances, admittances, and voltages are per phase wye for three-phase motors. Powers and volt-amperes are per complete motor.

$$g_{fe} = \frac{W_h}{mV_o^2} \left(1 + \frac{x_1}{x_M} \right)^2 \quad (\text{Eq 7})$$

$$r_{fe} = \frac{1}{g_{fe}} \quad (\text{Eq 8})$$

$$r_2' = \left(\frac{W_L}{mI_{1L}^2} - r_1' \right) \left(1 + \frac{x_2}{x_M} \right)^2 - \left(\frac{x_2}{x_1} \right)^2 (x_{1L}^2 g_{fe}) \quad (\text{Eq 9})$$

To determine the circuit parameters using Method 3 (see 6.7.1.2) use the procedure outlined in 6.7.1.2.2.

To determine the circuit parameters using Method 4 (see 6.7.1.2) use the procedure outlined in 6.7.1.2.3.

Nomenclature

V	= phase voltage, in V
f	= frequency, in Hz
I_1	= line or stator current, in A
I_2	= rotor current, in A
m	= number of phases
r_1	= stator resistance corrected to specified temperature, t_s , in Ω
r_1'	= stator resistance at temperature during no-load test, in Ω
r_1''	= stator resistance at temperature during impedance test, in Ω
r_2	= rotor resistance referred to stator at specified temperature, t_s , in Ω
r_2''	= rotor resistance referred to stator at temperature during impedance test, in Ω
x_1	= stator leakage reactance, in Ω
x_2	= rotor leakage reactance referred to stator, in Ω
x_M	= magnetizing reactance, in Ω
b_M	= magnetizing susceptance, in Ω^{-1}
r_e	= core resistance, in Ω
g_e	= core conductance, in Ω^{-1}
VAR	= reactive volt-ampere, in vars
W	= power, in W
W_h	= core loss, in W
W_f	= friction and windage loss, in W
W_{1L}	= stray-load loss, in W
	= $LL_s + LL_r$

Subscripts

L	= to impedance test
o	= quantities pertaining to no-load test or operation

NOTES: (1) For three-phase machines, the per phase wye stator resistance is one-half of the terminal-to-terminal resistance.
(2) Design A, B, C, and D motors are defined in NEMA MG-1-1993 [B3].

Figure 10—Method F-F1: Equivalent circuit nomenclature and equations for determining machine constants

10.6 Form F2—Method F

Machine _____ Serial No. _____ Model No. _____
 Type _____ Hp/kW _____ Voltage _____ Synchronous Speed _____ Frequency _____ Phases _____

Summary of Tests

No Load	
Line Current, in A I_o	Stator Power, in W W_o

Impedance Data at _____ Hz (f_1)		
Line Volts V_L	Line Current, in A I	Stator Power, in W W

Constants

V = _____ (V) (per phase)
 r_1 = _____ (Ω)
 r_2 = _____ (Ω)
 r_{fe} = _____ (Ω)
 x_1 = _____ (Ω)
 x_2 = _____ (Ω)
 $(x_1 + x_2)$ = _____ (Ω)
 b_M = _____ (M Ω)
 g_{fe} = _____ (M Ω)
 W_f = _____ (W)
 W_h = _____ (W)
 $W_{LL} +$ _____ * (W) at $I_f =$ _____ (A)

*See 5.4.2, 5.4.3, or 5.4.4.

Summary of Characteristics

Load, in % of rated	25	50	75	100	125	150
Horsepower, in kW						
Speed, in r/min						
Line Current, in A						
Efficiency, in %						
Power Factor, in %						

Figure 11—Form F2
Method F: Induction machine characteristics

10.7 Form F3—Methods F, F1, C/F, E/F, and E/F1

Serial No. _____ Model No. _____
Type _____ hp/kW _____ Voltage _____ Synchronous Speed _____ Phase _____ Frequency _____

Before starting calculation, fill in following items, obtained from previous tests.

$r_2 =$ _____ $V =$ phase volts _____ I_1 _____ and W_{1L} _____ from Form F-2

also all the items below that are marked with an asterisk.

Assume a value of s corresponding to expected full-load speed for full-load point and proportional values for other loads. For motor operation, s is positive. For generator operation, s is negative. Numbers in () represent item numbers.

Item	Description (Motoring)(Generating)	1	2	3	4	5	6
1	$s =$ slip, per unit						
2	r_2/s						
*3	x_2						
4	$Z_2^2 = (2)^2 + (3)^2$						
5	$g_1 = (2)/(4)$						
*6	g_2						
7	$g = (5) + (6)$						
8	$-b_2 = (3)/(4)$						
*9	$-b_M =$						
10	$-b = (8) + (9)$						
11	$Y^2 = (7)^2 + (10)^2$						
12	$r_g = (7)/(11)$						
*13	$r_1 =$ resistance per phase						
14	$r = (12) + (13)$						
15	$x_g = (10)/(11)$						
*16	$x_1 =$						
17	$x = (15) + (16)$						
18	$Z = \sqrt{(14)^2 + (17)^2}$						
19	$I_1 = V/(18)$						
20	$I_2 = I_1 / \sqrt{(4) \cdot (11)}$						
21	Stator Power, in $W_s = m \cdot (19)^2 \cdot (14)$						
22	Sec. Input = $m \cdot (20)^2 \cdot (2)$						
23	Stator $I^2R = m \cdot (19)^2 \cdot (13)$						
24	Core Loss = $m \cdot (19)^2 \cdot (6)/(11)$						
25	Sec. $I^2R = (1) \cdot (22)$						
26	Friction and Windage Loss						
27	$W_{1L} = W_{1L} \cdot [(20)/I_1]^2$						
28	Losses = Items (23) through (27)						
29	Shaft power, in $W_s = (21) \cdot (28)$						
30	Efficiency, in %, = (see below)						
31	Power Factor, in %, = $100 \cdot (14)/(18)$						
32	Shaft Power, in hp, = $(29)/745.7$						
33	Speed = $[1 - (1)] \cdot$ synchronous speed						
34	Torque = $K_T \cdot (29)/(33)$						

(30) Efficiency, in %, = $(29) \cdot 100/(21)$ for motoring operation
= $(21) \cdot 100/(29)$ for generating operation

For Torque in	$K_T =$
lb•ft	7.043
N•m	9.549

Figure 12—Form F3
Methods F, F1, C/F, E/F, and E//F1: Solution of equivalent circuit

Annex A

(informative)

Typical report of test form for routine tests on induction machines

Name of Manufacturer _____
 Address of Manufacturer _____
 Purchaser _____
 Date of Test _____
 Manufacturer's Order No. _____
 Purchaser's Order No. _____

Nameplate Data

Rated hp/kW	Service Factor	Rated Speed r/min	Phase	Frequency Hz	Volts	Amperes

Type	Frame	(Temp Rise by Method Indicated)	(Ambient Temp and Insulation Class)	Time Rating	Design Letter	Code Letter for Locked kVA/hp

Test Characteristics

Serial No.	No Load					Locked Rotor				Wound Rotor Open-Circuit Voltage	High Potential Test Voltage	Stator Winding Resistance Between Terminals	
	Volts	Frequency Hz	Speed r/min	Amperes	Kilo-watts*	Volts	Frequency Hz	Amperes	Kilo-watts*			Ohms	Temperature °C

*If measured, optional.

Notes:

Data on test from _____ machine
 (this or duplicate)

Approved by _____ Date _____
 (Engineer)

Figure A.1—Typical report of test form for routine tests on induction machines

Annex B

(informative)

Typical report of test form for induction machines

Name of Manufacturer _____ Manufacturer's Order No. _____
 Address of Manufacturer _____ Date of Test _____
 Serial No. _____ Purchaser's Order No. _____
 Model Number _____
 Purchaser _____

Nameplate Rating

Rated hp/kW	Service Factor	Rated Speed r/min	Phase	Frequency Hz	Volts	Amperes	Type	Frame

Temperature Rise

Conditions of Test				Temperature Rise _____ °C			
Hours Run	Line Volts	Line Amperes	Cooling Air, °C	Stator		Rotor	
				Windings	Windings		
				*By	*By		
				Method	Method		

Characteristics

Rated Slip percent	No-Load Line Current, amperes	Secondary Volts at Standstill	Secondary Amperes per Ring at Rated Load	Resistance at 25 °C (between lines), ohms
				Prim
				Sec

Break-Down Torque in _____ † with _____ % volts applied	Locked-Rotor Torque in _____ † with _____ % volts applied	Starting Current Amperes (locked rotor) with _____ % volts applied	Volts ac for _____ Sec.	
			Stotr	Rotor

Efficiencies and Power Factor

Efficiency, Percent			Power Factor, Percent		
Rated Load	75% Load	50% Load	Rated Load	75% Load	50% Load

Notes:

Data on test from _____ machine
(this or duplicate)

Approved by _____ Date _____
(Engineer)

*Indicate method as: Thermometer, Thermocouple, Resistance, or Embedded Detector.

†Indicate torque units as N·m or lb-ft.

Figure B.1—Typical report of test form for induction machines

Annex C

(informative)

Bibliography

[B1] IEEE Std 1-1986, IEEE Standard General Principles for Temperature Limits in the Rating of Electric Equipment and for the Evaluation of Electrical Insulation (ANSI).

[B2] IEEE Std 62-1978, IEEE Guide for Field Testing Power Apparatus Insulation (ANSI).

[B3] NEMA MG-1-1993, Motors and Generators.

[B4] NIST Handbook 150-10, Efficiency of Electric Motors (EEM).